

S T E A M

VULCAN**KEL SERIES
ELECTRIC FLOOR MOUNTED
STATIONARY 2/3 JACKETED KETTLE**

Model K40EL

**SPECIFICATIONS**

Electric self-contained, stainless steel, 2/3 jacketed floor mounted stationary steam kettle. Ellipsoidal bottom kettle liner formed and fully welded type 316 and type 304 stainless steel exterior with (1/4 x 5/8 inch 20 gallons) (3/8 x 1 inch 40 gallons and greater) bar rim, embossed gallon/liter markings and faucet bracket. 50 psi (3.4 kg/cm²) steam jacket rating. Spring assist hinged stainless steel cover with condensate ring and drop down lift handle with heavy duty pivot assembly that includes a yolk style mount with tie bar. Two inch compression tangent draw-off valve with perforated strainer. Tubular stainless steel legs with flanged feet. Stainless steel enclosure for "water resistant" controls. Controls include a power switch, power "on" light, solid state temperature control, vacuum/pressure gauge, pressure relief valve, low water light and low water shut-off.

UL listed. UL Classified for sanitation in accordance with ANSI/NSF Standard #4. Meets ASME code.

- K20EL** 12 KW, 20 gallon true working capacity
- K40EL** 18 KW, 40 gallon true working capacity
- K60EL** 18 KW, 60 gallon true working capacity

STANDARD FEATURES

- Electric self-contained, stainless steel, 2/3 jacketed floor mounted stationary steam kettle.
- Ellipsoidal bottom kettle liner formed and fully welded standard type 316 and type 304 stainless steel exterior.
- Heavy bar rim (1/4 x 5/8 inch 20 gallons) (3/8 x 1 inch 40 gallons and greater).
- Embossed gallon/liter markings.
- Faucet bracket.
- 50 psi (3.4 kg/cm²) steam jacket rating.
- Spring assist hinged stainless steel cover with condensate ring and drop down lift handle with heavy duty pivot assembly that includes a yolk style mount with tie bar.
- Two inch compression tangent draw-off valve with perforated strainer.
- Tubular stainless steel legs with flanged feet.
- Stainless steel enclosure for "water resistant" controls.
- Controls include a power switch, power "on" light, solid state temperature control, vacuum/pressure gauge, pressure relief valve, low water light and low water shut-off.
- One year limited parts and labor warranty.

OPTIONS

- Two inch plug tangent draw-off valve with perforated strainer.
- Three inch compression tangent draw-off valve with perforated strainer.
- Security facility package:
 - a. Security type fasteners with tack welds.
 - b. Stainless steel step over draw-off valve with chain.
- 480 volt, 60 Hz, 3 phase power supply.
- Increase to 24 kW for 40 - 60 gallon models (3 phase only).
- Second year extended limited parts and labor warranty.

ACCESSORIES (Packaged & Sold Separately)

- Clean-up kit, includes draw-off brush, clean-up brush and paddle scrapper with 40" handle.
- Stainless steel 48" whip.
- Non-perforated strainer.
- (12") (18" double jointed) single pantry lead-free faucet.
- (12") (18" double jointed) double pantry lead-free faucet.
- Double pantry washdown hose with 16" add-on lead-free faucet with vacuum breaker.
- Double pantry washdown hose with lead-free vacuum breaker.
- Double pantry pot filler with lead-free vacuum breaker.

VULCAN

a division of ITW Food Equipment Group LLC

P.O. Box 696 ■ Louisville, KY 40201 ■ Toll-free: 1-800-814-2028 ■ Local: 502-778-2791 ■ Quote & Order Fax: 1-800-444-0602



KEL SERIES ELECTRIC FLOOR MOUNTED STATIONARY 2/3 JACKETED KETTLE

SERVICE CONNECTIONS

Electrical Connection: Single point supply 1 1/8" (29 mm) dia. (3/4" conduit).

Water Connection: Only for faucet accessory.

TRUE WORKING CAPACITIES (in 4 oz. servings)

80 quarts/20 gallons/76 liters/640 servings
120 quarts/40 gallons/152 liters/1,280 servings
160 quarts/60 gallons/228 liters/1,920 servings

NOTE:

- Dimensions which locate the above connections have a tolerance of + or -3" (+ or -75 mm).
- Installation of backflow preventers, vacuum breakers and other specific code requirements is the responsibility of the owner and installer. It is the responsibility of the owner and installer to comply with local codes.
- This appliance is manufactured for commercial installation only and is not intended for home use.

	STANDARD DEVICE	STANDARD DEVICE	OPTIONAL DEVICE
	Shipped for 208/50/60/3 electrical service. Can be field converted to 208/50/60/1 and 240/50/60/3 and 240/50/60/1	Shipped for 208/50/60/3 electrical service. Can be field converted to 208/50/60/1	Shipped for 240/50/60/3 electrical service. Can be field converted to 240/50/60/1
K20EL	✓	N/A	N/A
K40EL	N/A	✓	✓
K60EL	N/A	✓	✓

MODEL	kW	PHASE	AMPERAGE PER LINE			MINIMUM CIRCUIT AMPACITY		
			208V	240V	480V	208V	240V	480V
K20EL	12	1	57.7	—	—	75	—	—
		3	33.3	—	14.4	45	—	20
	16	1	—	66.7	—	—	85	—
		3	—	38.5	—	—	50	—
Standard K40EL K60EL	18	3	50.0	43.3	21.7	65	55	30

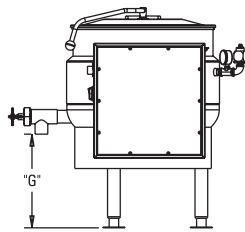
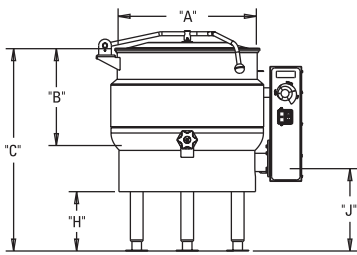
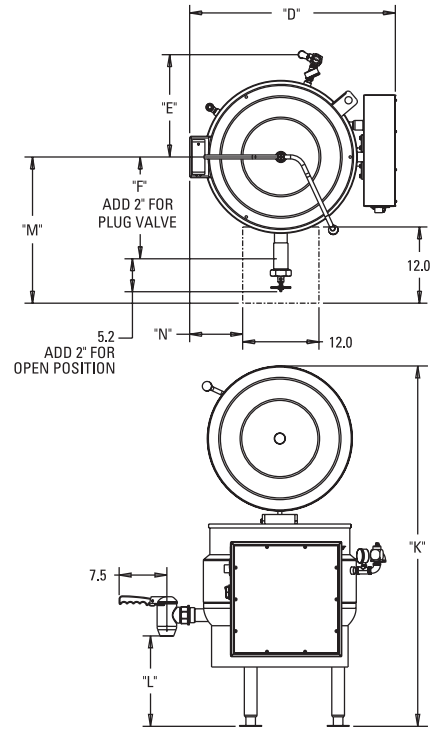

MODEL	TRUE WORKING CAPACITY	A	B	C	D	E	F	G	H	J	K	L	M	N
K20EL	20 gallons	21.6	15.2	31.86	32.5	16	16	14.7	9.3	13.9	56.7	14.3	23	8.3
	76 liters	549	386	810	826	406	406	374	236	353	1440	363	586	211
K40EL	40 gallons	25.8	21.2	37.1	37.7	17.5	17.75	14	10.5	12.8	65.8	13.5	24.8	10.5
	152 liters	656	538	942	958	445	451	356	267	325	1671	343	632	267
K60EL	60 gallons	29.5	23.9	39.5	40.5	17	19.7	13.5	8	12.2	72.4	13	27.5	12.2
	227 liters	749	607	1003	1029	432	500	343	203	310	1842	330	700	310



a division of ITW Food Equipment Group LLC

P.O. Box 696 ■ Louisville, KY 40201 ■ Toll-free: 1-800-814-2028 ■ Local: 502-778-2791 ■ Quote & Order Fax: 1-800-444-0602

NOTE: In line with its policy to continually improve its products, Vulcan reserves the right to change materials and specifications without notice.