



PROJECT: _____
 ITEM # _____ QTY: _____
 MODEL # _____
 AIA # _____ SIS # _____

UNDERCOUNTER FREEZER

UNDERCOUNTER FREEZER

VUF48HC



CABINET CONSTRUCTION

- Stainless Steel Exterior (galvanized back and bottom)
- Aluminum Interior
- Stainless Steel 20 Gauge Doors
- One Piece, Snap-In Magnetic Door Gaskets
- 6" Casters Two With Brakes
- 8' Cord And Plug (see electrical data for details)

FEATURES

- Full Electronic Control
- Stay-Open Door Feature For Easy Product Loading
- Heavy-Duty, Spring Loaded Cartridge Hinges
- Low Profile Horizontal Door Handles
- Epoxy Coated Shelves (2 per section)

REFRIGERATION

- Refrigeration System Uses R-290 Refrigerant To Comply With All Environmental Concerns
- Rear Mounted Refrigeration System
- Adaptive Defrost For Reduced Energy Consumption And More Consistent Product Temperatures
- Epoxy Coated Evaporator Coil
- Freezer Capable Of Maintaining Product Temperature -10°F

- ▶ **3 Year Parts & Labor Warranty Plus An Additional 4 Year Compressor Warranty**
- ▶ **Exclusive 2 Year Warranty On Magnetic Door Gaskets**
- ▶ **Lifetime Warranty On Handles & Hinges (parts only)**



Please verify qualifying units by visiting:
www.energystar.gov/cfs

OPTIONS & ACCESSORIES

- | | | |
|---|--|---|
| • Stainless Steel Interior | • Cutting Board | • Correctional Package |
| • Stainless Steel Back | • Additional Shelves | • Remote Models* (6" legs only)
(refrigerant must be specified at time of order, see note on back on page) |
| • Secure-Temp™ Technology | • Shelf Clips (set of 4) | |
| • Door Locks | • Casters: 3", Roller Kit, Low Profile | |
| • Door Swing Orientation (at time of order) | • 6" Legs Or 6" Seismic Legs | |

3779 Champion Blvd, Winston-Salem, NC 27105

ph: (888) 845-9800 | fax: (800) 253-5168

Sales@VictoryRefrigeration.com | VictoryRefrigeration.com

Rev. 11/2/21 Printed in U.S.A.

APPROVAL: _____ DATE: _____



UNDERCOUNTER FREEZER

VUF48HC

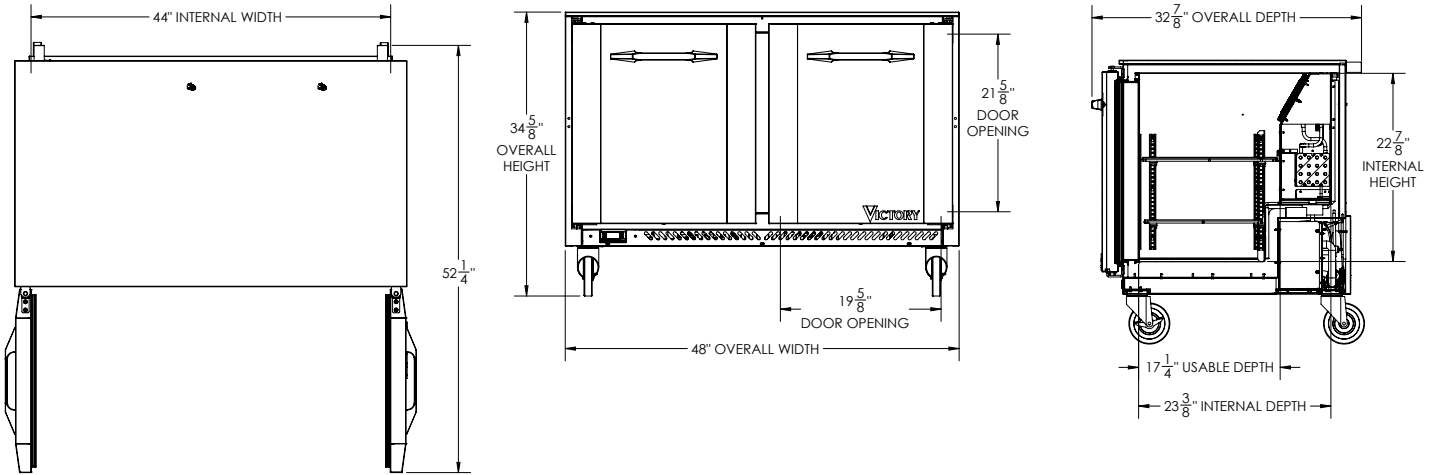

We reserve the right to change specifications and product design without notice. Such revisions do not entitle the buyer to corresponding changes, improvements, additions or replacements for previously purchased equipment. Dimensional tolerances +/- 1/4". Metric dimensions (MM)

CHARACTERISTICS		ELECTRICAL DATA		SHIPPING DETAILS	
Net Capacity (cubic ft.)	11.04	Cabinet Voltage	115/60/1	Height	48"
Width, Overall (in.)	48"	Total Amperes	7.0	Width	50"
Depth, Overall (with handle)	32 7/8"	NEMA Plug (8' cord)	5-15P	Depth	37"
Height Overall (6" casters)	34 5/8"	REFRIGERATION DATA		Crated Weight	312 lbs
Depth, Door Open 90°	52 1/4"	Condensing Unit Size, HP	1/2	*NOTE: Remote units are field wired and comes with 6" legs. Refrigerant must be specified at time of order.	
Door Opening (in.)	19 5/8" x 21 5/8"	Refrigerant*	R-290		
No. Of Door/Shelves	2/4	Capacity (BTU/HR) (100°F/20°F)	1865		
		Heat Rejection (BTU/HR)	2797.5		
		Charge (lbs/grams)	0.165/75		

3779 Champion Blvd, Winston-Salem, NC 27105 | ph: (888) 845-9800 | fax: (800) 253-5168

Sales@VictoryRefrigeration.com | VictoryRefrigeration.com

Rev. 11/2/21 Printed in U.S.A.

an Ali Group Company



The Spirit of Excellence