

# VICTORY

PROJECT: \_\_\_\_\_  
ITEM # \_\_\_\_\_ QTY: \_\_\_\_\_  
MODEL # \_\_\_\_\_  
AIA # \_\_\_\_\_ SIS # \_\_\_\_\_

PIZZA PREP TABLE WITH DRAWERS

## PIZZA PREP TABLE WITH DRAWERS

### VPPD60HC-2



#### CABINET CONSTRUCTION

- Stainless Steel Exterior (galvanized back and bottom)
- Aluminum Interior
- Hinged, Insulated, Flat Lift-Up Lids
- One-Piece, Snap-In Magnetic Drawer Gaskets
- Heavy-Duty Aluminum Pan Liner
- 8' Cord And Plug (see electrical data for details)

#### REFRIGERATION

- Refrigeration System Uses R-290 Refrigerant To Comply With All Environmental Concerns
- Side Mounted Refrigeration System for Serviceability
- Adaptive Defrost For Reduced Energy Consumption And More Consistent Product Temperatures
- Epoxy Coated Evaporator Coil
- Refrigerator Capable Of Maintaining Product Temperature 36°F to 38°F

#### FEATURES

- Full Electronic Control
- Low Profile Horizontal Drawer Handles
- Stay-Open Drawer Feature For Easy Product Loading
- Heavy-Duty Stainless Steel Drawer Frames
- Heavy-Duty Pan Divider Supports Supplied
- Locking Divider Bars (drawers only)
- Top Accommodates 6" Deep Food Service Pans (pans not included)
- Accommodates 6" Deep Full Size Food Service Pans In Both Upper And Lower Drawers (pans not included)
- Heavy-Duty, Telescoping Drawer Slides With Locking Mechanism
- 275 lbs Drawer Load Rating (per drawer)
- Removable 19" Wide Cutting Board
- 3" Casters Two With Locks

- ▶ **3 Year Parts & Labor Warranty**  
**Plus An Additional 4 Year Compressor Warranty**
- ▶ **Exclusive 2 Year Warranty On Magnetic Drawer Gaskets**
- ▶ **Lifetime Warranty On Handles And Drawer Slides (Parts Only)**

#### OPTIONS & ACCESSORIES

- Stainless Steel Interior
- Exterior Door Laminate
- 6" Casters, 6" Legs Or 6" Seismic Legs
- Stainless Steel Back
- Drawer Locks
- Compressor On Left (specify at time of order)
- Secure-Temp™ Technology
- Single & Double Overshelf Kit
- Remote Models\* (6" legs only)  
(refrigerant must be specified at time of order, see note on back on page)



Please verify qualifying units by visiting:  
[www.energystar.gov/cfs](http://www.energystar.gov/cfs)

3779 Champion Blvd, Winston-Salem, NC 27105

ph: (888) 845-9800 | fax: (800) 253-5168

Sales@VictoryRefrigeration.com | VictoryRefrigeration.com

Rev. 4/20/20 Printed in U.S.A.

APPROVAL: \_\_\_\_\_ DATE: \_\_\_\_\_

# VICTORY PIZZA PREP TABLE WITH DRAWERS

## VPPD60HC-2

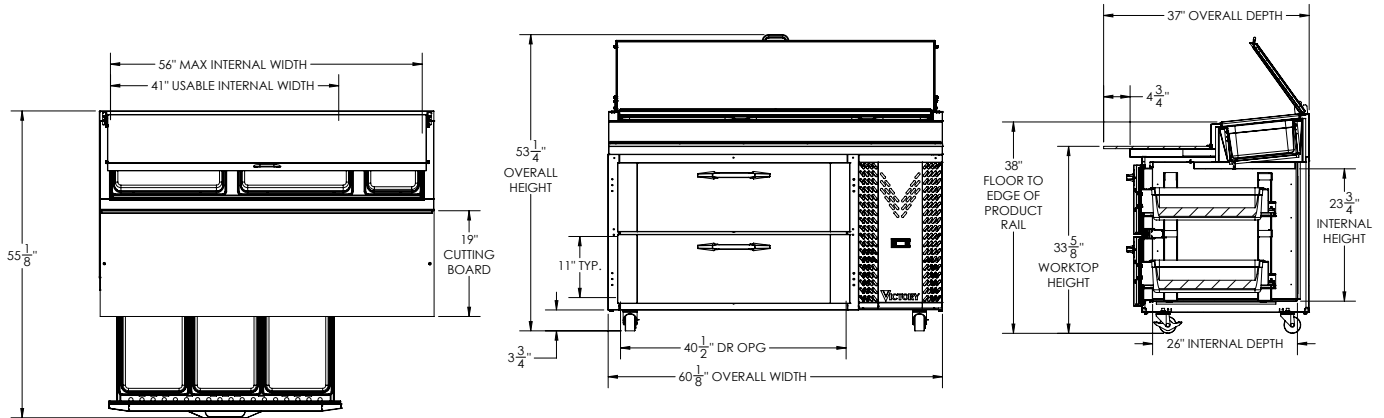

We reserve the right to change specifications and product design without notice. Such revisions do not entitle the buyer to corresponding changes, improvements, additions or replacements for previously purchased equipment. Dimensional tolerances +/- 1/4". Metric dimensions (MM)

CHARACTERISTICS		ELECTRICAL DATA		SHIPPING DETAILS	
Net Capacity (ft <sup>3</sup> )	17.76	Cabinet Voltage	115/60/1	Height	47"
Width, Overall (in.)	60 1/8"	Total Amperes	4.5	Width	66"
Depth, Overall (with cutting board)	37"	NEMA Plug* (8' cord)	5-15P	Depth	40"
Height Overall (3.75" casters)	53 1/4"	REFRIGERATION DATA		Created Weight	490 lbs
Depth, Door Extended	55 1/8"	Condensing Unit Size, HP*	1/2 HP	*NOTE: Remote units are field wired and come with 6" legs. Refrigerant must be specified at time of order.	
Drawer Opening (in.)	40 1/2" x 11"	Refrigerant*	R290		
No. Of Drawers	2	Capacity (BTU/HR) (100°F/20°)	2940		

3779 Champion Blvd, Winston-Salem, NC 27105 | ph: (888) 845-9800 | fax: (800) 253-5168

Sales@VictoryRefrigeration.com | VictoryRefrigeration.com

Rev. 4/20/20 Printed in U.S.A.

an Ali Group Company



The Spirit of Excellence