

REFRIGERATOR MANUFACTURER
Turbo air
 more durable, efficient, beautiful

4184 E. Conant St.
 Long Beach, CA 90808
 Tel. 310-900-1000
 Fax. 310-900-1077
www.turboairinc.com

Project :	
Model # :	
Item # :	Qty :
Available W/H :	
Approval :	

Swing Door Freezers

Glass Door Merchandisers
 Freezers

Model : TGF-49F(B)-N

FEATURES & BENEFITS

- **Digital temperature control & monitor system**

 - Keep food products safe by maintaining constant temperatures.
 - Alarms that sound when doors are not sealed shut; protect against food spoilage that originates from cold air leaks.
 - Digital display allows for easy monitoring.
 - Programs interpret the condition of refrigeration systems by self-diagnosis.
 - Rapid cool-down function (Turbo Freeze).
 - Smart defrost system will defrost as needed.
 - Automatic evaporator fan motor delays.
- **Hydrocarbon refrigerants (R-290)**

With innovative and eco-friendly technology, Turbo Air brings you hydrocarbon refrigerators designed to meet DOE's Energy Conservation Standards in 2017 and to use EPA's SNAP Program approved HC refrigerants. Hydrocarbon refrigerants do not deplete the ozone layer and have very low contribution to global warming (ODP-0, GWP-3).
- **Triple pane heated glass doors**

Equipped with unique triple-pane heated glass doors which enhance energy efficiency by preventing heat transfers and minimizing condensation. Lightweight door construction reduces door maintenance, bushing wear, and facilitates smooth door opening.
- **High-density polyurethane insulation**

The entire cabinet structure is foamed-in-place using high density, HCFC free polyurethane insulation.
- **Ergonomically designed doors**

Customers' fatigue fades away with easy grip handles and doors that open effortlessly. These features along with self-closing doors make this the ultimate choice in customer convenience.
- **LED advertising panel**

LED lighting offers 5 times longer lasting life than fluorescents and conserves energy as well.
- **Adjustable, heavy duty, PE (polyethylene) coated wire shelves**
- **LED interior lighting**
- **Freezer holds -10°F ~ 5°F for the best in frozen food preservation**



TGF-49FB-N

TGF-49F-N

Only at Turbo Air, Only in the World

Turbo Air's 2 & 3 Glass Door Freezers are powered by 115V. Not only is our 115V simple and easy to plug in and operate, it also saves customers over \$1,000 in electrical line installation for 220V powered glass door freezers. We are the only company to have achieved this feat, which is proof of our dedication to energy efficiency and the environment.



Model	Swing Door	CU./FT.	#of Shelves	HP	AMPS	Crated Weight (lbs.)	L x D x H (inches)
TGF-49F(B)-N	2	39.88	8	1	9.8	587	543/8 x 293/4 x 781/4

Model : TGF-49F(B)-N

ELECTRICAL DATA	
Voltage	115/60/1
Plug Type	Ⓢ NEMA 5-20P
Full Load Amperes	9.8
Compressor HP	1
Cord Length (ft.)	7
Refrigerant	R-290
DIMENSIONAL DATA	
# of Doors	2
Net Capacity (cu. ft.)	39.88
Ext. Length Overall (in.)	54 ³ / ₈ (1382mm)
Ext. Depth Overall (in.)*	29 ³ / ₄ (756mm)
Ext. Height Overall (in.)	78 ¹ / ₄ (1987mm)
Int. Length Overall (in.)	50 ¹ / ₂ (1283mm)
Int. Depth Overall (in.)	24 ¹ / ₈ (614mm)
Int. Height Overall (in.)	60 ³ / ₈ (1535mm)
# of Shelves	8
Shelf Size (L x D) (in.)	24 ³ / ₄ x 23
Net Weight (lbs.)	554
Gross Weight (lbs.)	587

Design and specifications subject to change without notice.
Actual shipping weight may differ due to extra packing materials for product protection.
* Depth does not include 1-3/8" for glass door handles.

■ **WARRANTY : 2 Year Parts and Labor Warranty
Additional 3 Year Warranty on Compressor**

■ **STANDARD FEATURES**

- Anti-corrosion coated evaporator
- Magnetic door gaskets
- White and black color come standard

■ **OPTIONAL ACCESSORIES**

- 4" casters, 1/2" diameter & 13 TPI: G8F6500101 (non-brake), G8F6500201 (w/ brake)
- Additional PE coated wire shelf: 30250R0600 (Left), 30250R0500(Right)
- Price tag channel: P0122K5200 (21"L)
- Sign panel (blank): 30274R0100-BLNK

PLAN VIEW

(unit : inch)

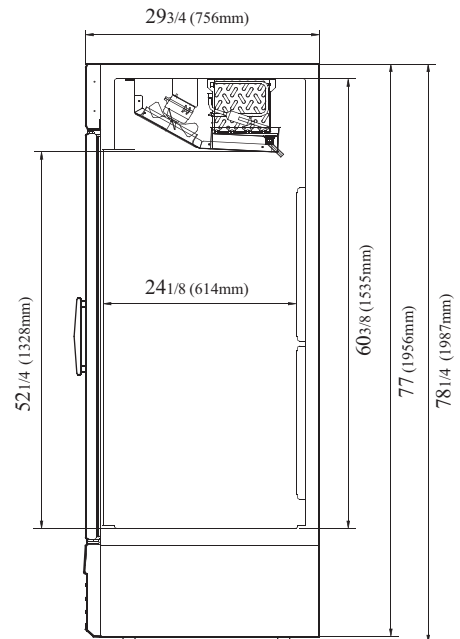
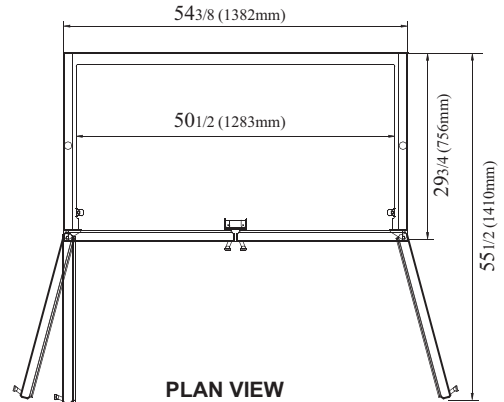

Ver.20200825



- Turbo Air : 800-627-0032
- GK : 800-500-3519
- Warranty : 800-381-7770
- AC : 888-900-1002