

FF711ESLLF2



46" x 18.75" x 23" (H x W x D)

Two-door refrigerator-freezer in slim 18" width, with combination lock to secure both doors

Highlights:

Combination lock secures both refrigerator and freezer sections

Two-door design for convenience and efficiency

Slim width is ideal for space-challenged locations

Product Features:

CEE Tier II qualified	Efficient design meets CEE Tier II specifications, using 25% less energy than DOE standards require for this product category
Thin-line design	Slim width under 19" for an easy fit in space-challenged settings
LLF2 lock	Combination lock with key override secures both sections
Frost-free operation	No-frost convenience for reduced user maintenance
Reversible doors	Keep your options flexible with reversible doors that are easy to switch when your arrangement changes
Adjustable shelves	Rearrange refrigerator space to accommodate all sizes or remove shelves for simple cleanup
Clear crisper drawer	Get the longest life and best taste out of produce by storing greens in a bottom crisper
Interior light	Automatically illuminates when you open the door
Door storage	Store tall bottles and condiments right on the door for convenient access

FF711ESLLF2 Specifications:

Overview	
Height of Cabinet	46.0" (117 cm)
Width	18.75" (48 cm)
Depth	23.0" (58 cm)
Capacity	4.8 cu.ft. (136 L)
Defrost Type	Frost-Free
Door	White
Cabinet	White
US Electrical Safety	UL
Canadian Electrical Safety	ULC
Energy Usage/Year	346.0kWh/year
Amps	0.9
Voltage/Frequency	115 V AC/60 Hz
Weight	102.0 lbs. (46 kg)
Shipping Weight	107.0 lbs. (49 kg)
Parts & Labor Warranty	1 Year
Compressor Warranty	5 Years
UPC	761101084558
Refrigerator-Freezer	
Door Swing	RHD
Reversible	Yes
Adjustable Shelves	Yes
Crisper Qty	1
Crisper Finish	Transparent
Crisper Cover	Glass
Interior Light	Yes
Refrigerator - Interior Height	24.75" (63 cm)
Refrigerator - Interior Width	16.25" (41 cm)
Refrigerator - Interior Depth	15.75" (40 cm)
Refrigerator - Capacity	3.7 cu.ft
Refrigerator - Shelf Type	Wire
Refrigerator - Shelf Qty	2
Refrigerator - Full Door Shelves	3
Freezer - Interior Height	13.5" (34 cm)
Freezer - Interior Width	17.88" (45 cm)
Freezer - Interior Depth	12.5" (32 cm)

Freezer - Capacity	1.1 cu.ft
Freezer - Shelf Type	Wire
Freezer - Shelf Qty	1
Freezer - Full Door Shelves	2
Thermostat Type	Dial
Fan Type	Interior
Refrigerant Type	R600a
Refrigerant Amount	1.2 oz.
Level Legs	2
Compressor Step Height	6.0" (15 cm)
Compressor Step Width	16.25" (41 cm)
Compressor Step Depth	6.5" (17 cm)



U.S. Government

Federal law prohibits removal of this label before consumer purchase.

ENERGYGUIDE

Refrigerator-Freezer

- Automatic Defrost
- Top-Mounted Freezer
- No through-the-door ice

Felix Storch, Inc.

Model FF711ESLLF2

Capacity: 4.8 Cubic Feet



Compare ONLY to other labels with yellow numbers.
 Labels with yellow numbers are based on the same test procedures.

Estimated Yearly Energy Cost

\$44

Cost Ranges

Models with similar features

\$36

\$53

All models

\$18

\$70

346 kWh

Estimated Yearly Electricity Use



- Your cost will depend on your utility rates and use.
- Both cost ranges based on models of similar size capacity.
- Models with similar features have automatic defrost, top-mounted freezer, and no through-the-door ice.
- Estimated energy cost based on a national average electricity cost of 12.9 cents per kWh.

ftc.gov/energy



COMPACT REFRIGERATOR-FREEZER

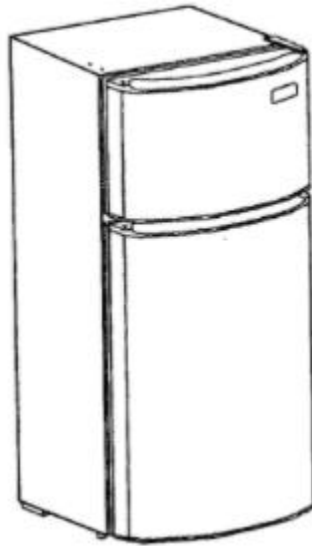

Model: FF711ES

User Manual

BEFORE USE, PLEASE READ AND FOLLOW ALL SAFETY RULES AND OPERATING INSTRUCTIONS

ATTENTION

For your protection in the event of theft or loss of refrigerator, fill in spaces provided below. Model and Serial Numbers are indicated on rear wall of refrigerator.

MODEL No. _____

SERIAL No. _____

Felix Storch, Inc.
An ISO 9001:2015 registered company
770 Garrison Ave
Bronx, New York 10474
www.summitappliance.com

TABLE OF CONTENTS

<i>Important Safeguards</i>	3-4
<i>Location of Parts</i>	5
<i>Installing your Refrigerator</i>	6
<i>Test Run</i>	6
<i>Reversing the Door Swing</i>	7-8
<i>Temperature Control</i>	8
<i>Removing Ice Cubes from the Tray</i>	9
<i>Cleaning and Care</i>	9
<i>Troubleshooting</i>	10
<i>Limited Warranty</i>	12

IMPORTANT SAFEGUARDS

Before the appliance is used, it must be properly positioned and installed as described in this manual, so please read the manual carefully. To reduce the risk of fire, electrical shock, or injury when using the appliance, follow basic precautions, including the following:

- Plug into a grounded 3-prong outlet, do not remove the grounding prong, do not use an adapter, and do not use an extension cord.
- It is recommended that a separate circuit, serving only your appliance be provided. Use receptacles that cannot be turned off by a switch or pull chain.
- Never clean the freezer with flammable fluids. These fumes can create a fire hazard or explosion.
- Do not store or use gasoline or other flammable vapors and liquids inside or in the vicinity of this or any other appliance. The fumes can create a fire hazard or explosion.
- Do not use inflammable sprays in the vicinity of the appliance.
- Before proceeding with cleaning and maintenance operations, make sure the power line of the unit is disconnected.
- Do not connect or disconnect the electric plug when your hands are wet.
- Unplug the appliance or disconnect power before cleaning or servicing. Failure to do so can result in electrical shock or death.
- Do not attempt to repair or replace any part of your appliance, unless it is specifically recommended in this manual. All other servicing should be referred to a qualified technician.
- This appliance is CFC- and HFC-free and contains a small quantity of Isobutane (R600a), which is environmentally friendly but flammable. It does not damage the ozone layer, nor does it increase the greenhouse effect. Care must be taken during transportation and setting up of the appliance that no parts of the cooling system are damaged. Leaking coolant can ignite and may damage the eyes.
- In the event of any damage:
 - Avoid open flames and anything that creates a spark,
 - Disconnect from the electrical power line,
 - Air the room in which the appliance is located for several minutes, and
 - Contact the Service Department for advice.
 - In case the power supply cord is damaged, it must be replaced by a service agent or a similarly qualified person to avoid a potential hazard
- The more coolant there is in an appliance, the larger the room it should be installed in. In the event of a leakage, if the appliance is in a small room, there is the danger of combustible gases building up. For every ounce of coolant, at least 325 cubic feet of room space is required. The amount of coolant in the appliance is stated on the data plate on the appliance. It is hazardous for anyone other than an Authorized Service Person to carry out servicing or repairs to this appliance.
- Take serious care when handling, moving, and using the appliance to avoid either damaging the refrigerant tubing or increasing the risk of a leak.
- Replacing component parts and servicing shall be done by factory authorized service personnel so as to minimize the risk of possible ignition due to incorrect parts or improper service.

WARNING

- Use two or more people to move and install the appliance. Failure to do so can result in back or other injury.
- To ensure proper ventilation for your appliance. The front of the unit must be completely unobstructed. Choose a well-ventilated area with temperature above 60°F (16°C) and below 90°F (32°C). This unit must be installed in an area protected from the elements, such as wind, rain, water spray, or drips.
- The appliance should not be located next to ovens, grills, or other sources of high heat.
- The appliance must be installed with all electrical, water, and drain connections in accordance with state and local codes. A standard electrical supply (115V AC only, 60 Hz), properly grounded in accordance with the National Electric Code and local codes and ordinances required.
- Do not kink or pinch the power supply cord with the appliance.
- The fuse (or circuit breaker) size should be 15 amperes.
- It is important for the appliance to be levelled in order to work properly. You may need to make several adjustments to level it. Check for leaks after connection.
- This appliance is not intended for use by persons (including children) with reduced physical, sensory, or mental capabilities, or lack of experience and knowledge, unless they have been given supervision or instruction concerning use of the appliance by a person responsible for their safety.
- **IMPORTANT:** Do not use mechanical devices or other means to accelerate the defrosting process, other than those recommended by the manufacturer.
- **IMPORTANT:** Do not damage the refrigerant circuit.
- **IMPORTANT:** Do not use electrical appliances inside the storage compartment of the appliance, unless they are the type recommended by the manufacturer.
- Do not use solvent-based cleaning agents or abrasives on the interior. These cleaners may damage or discolour the interior.
- Do not use this apparatus for other than its intended purpose.

DANGER

- An empty refrigerator is a very dangerous attraction to children. Remove the gasket, latches, lids, or doors from unused appliances, or take some other action that will guarantee the appliance is harmless.
- **CAUTION:** *Risk of child entrapment. Before you throw away your old refrigerator:*
 - *Take off the doors.*
 - *Leave the shelves in place so that children may not easily climb in.*

SAVE THESE INSTRUCTIONS

LOCATION OF PARTS

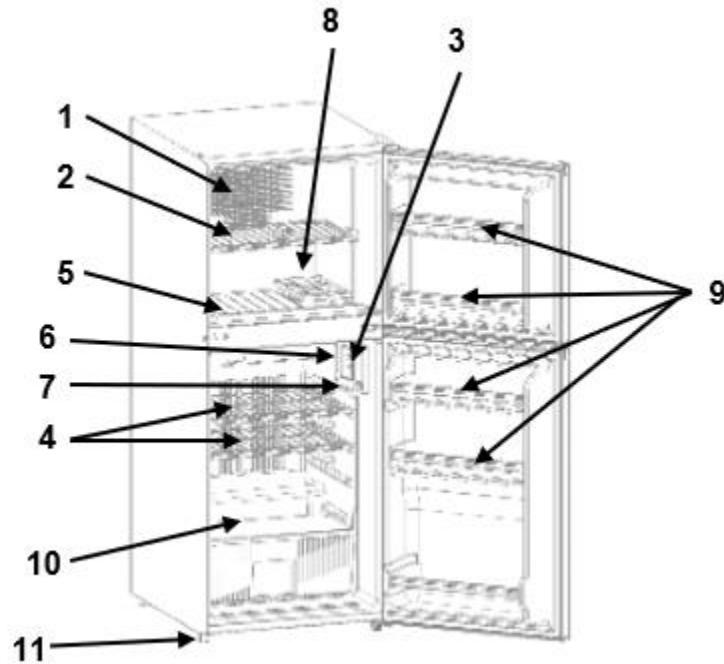

No. Part Name

1. Discharge Outlet
2. Freezer Shelf
3. Temperature Control
4. Plastic coated Shelves
5. Suction Inlet
6. Interior Light
7. Interior Light Switch
8. Ice Cube Tray
9. Panel Guard
10. Glass Shelf
11. Leveling leg

Description

Since cold air flows through this outlet into the refrigerator, be sure to avoid blocking it with stored food.

Air that circulates throughout the refrigerator flows through this opening to regulate the temperature inside the refrigerator.

INSTALLING YOUR REFRIGERATOR

- This appliance is intended to be used in household or similar applications.
- To use your appliance with the most efficiency and safety, select a suitable place installation according to the following:
 1. This appliance is designed for free-standing installation only, and should not be recessed or built-in.
 2. The appliance should be installed on a strong level floor or counter. If the floor is not quite level, adjust the leveling feet.
 3. A minimum of 3 inches of clearance must be provided between the rear condenser and wall. Also, allow 2 inches of space on the sides and 12 inches on the top. If another appliance, such as a microwave, is placed on top, allow 4 inches of space above it. Providing greater rear wall clearance when space allows in order to improve air circulation is recommended.
 4. Avoid any direct sunlight, heat, and moisture.
 5. This appliance is equipped with a three-prong plug and is grounded to eliminate electrical hazards. In order to make it effective, the appliance must be plugged into a ground electrical outlet.
 6. Do not use an extension cord.

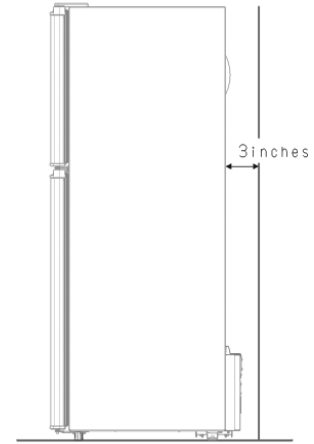

TEST RUN

Before using the refrigerator, clean it and make a test run to see if the following are completed. If not, check the electricity supply. If the cause of trouble cannot be located, contact your Summit dealer.

1. Plug the AC cord into an electrical outlet of 115 volt, 60Hz, set FRIDGE CONTROL to "COLDEST", and let the refrigerator operate for 10 minutes. Cold air should flow through the discharge outlet, and the compressor motor should run smoothly with a soft hum.
2. When the COOL POWER button is pressed for at least three (3) seconds, the OFF-LED light turns on, and the refrigerator stops operating. Wait at least five (5) minutes, then press COOL POWER button for at least three (3) seconds again. The OFF-LED turns off, and the refrigerator resumes operation. Be sure to turn off COOL POWER OFF mode. Otherwise, the refrigerator will not operate.
3. If the FRIDGE CONTROL button is set to "COLD" after running refrigerator for more than 100 minutes, the compressor motor will turn off.

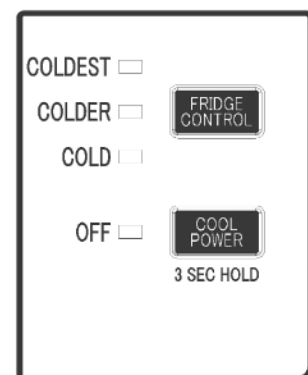

ATTENTION:

If the unit is turned off or unplugged, **YOU MUST ALLOW FIVE (5) MINUTES BEFORE RESTARTING OR REPLUGGING THE UNIT.** The unit may not start if you attempt to restart it in less than (5) minutes.

REVERSING THE DOOR SWING

Refer to the disassembly diagram, and change the door hinges in the following procedure. The numbers in the diagram indicate the procedure order in the instructions.

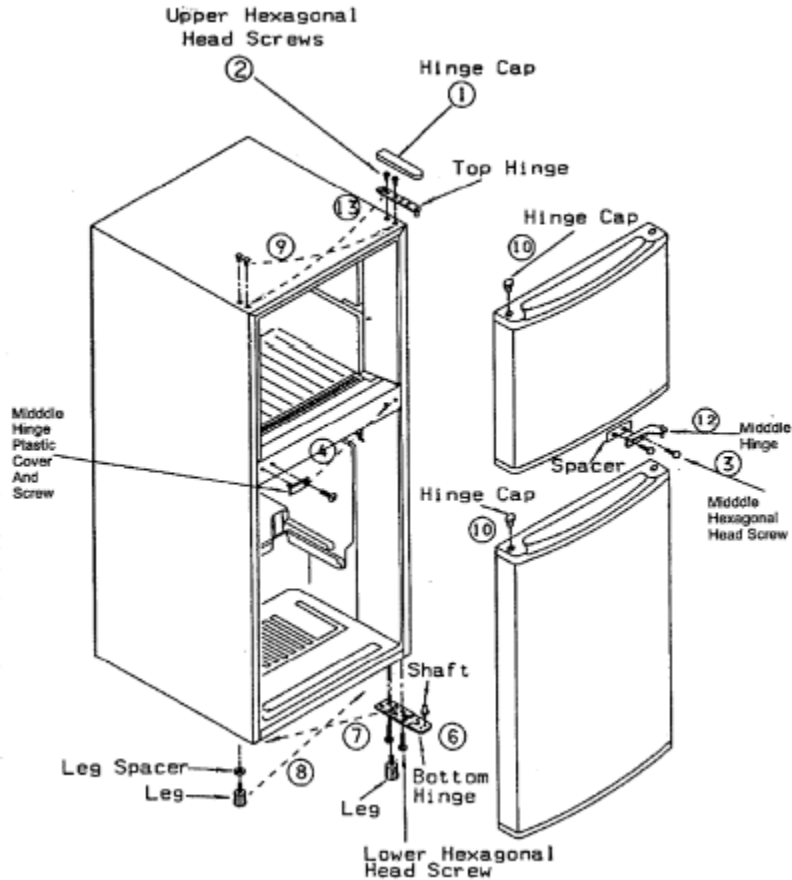

1. Remove the hinge cap by twisting it off.
2. Remove the upper hexagonal head screws. The top hinge and the freezer door can now be removed.
3. Remove the middle hexagonal head screws. The middle hinge and the refrigerator door can now be removed.
4. Remove the cover for the middle hinge holes, and re-attach it symmetrically to the holes on the other side.
5. Tilt the refrigerator back or lay it on its back for steps 6, 7, and 8. Use a pad or blanket to protect the floor and to avoid scratching the painted finish.
6. Remove the leveling legs by turning them counterclockwise. Remove the lower hexagonal head screws, two on the hinge side and one near the front corner of the other side.
7. Attach the bottom hinge symmetrically to the other side of the cabinet with the screws removed in step 6. (Do not tighten the screws completely.)
8. Attach the left side leg and the leg spacer to the other side hole when was positioned symmetrically.
9. Remove the upper hinge plastic pins, and insert them in the holes from which the screws were removed in step 2.
10. Take off the hinge collar caps from both the freezer and refrigerator doors using a screwdriver and insert them in the hinge collars on the opposite sides.

11. Attach the shaft to the hinge bottom. Attach the refrigerator door to the shaft.
12. Rotate the middle hinge 180°. Attach it to the refrigerator door and secure it with a screw. (Do not tighten the screws completely.)
13. Attach the upper hinge to the freezer door. Attach the freezer door to the middle hinge and use the screws to attach the upper hinge. (Do not tighten the screws completely.)
14. The direction in which the door opens has now been changed, however, the following points should be checked:
 - a. Make sure the door is straight.
 - b. Make sure that there is no space between the door gasket and the refrigerator unit itself when the door is closed.
 - c. Make sure that the gasket on the hinge side is not caught between the door and the unit when the door is opened or closed. (If the door is forced closed when the gasket is caught, the gasket may be damaged.)

When checking the above points, if it is discovered that the door is not installed properly (this is apt to happen at the first try), loosen the screws slowly with a socket wrench. After making sure that the door is installed correctly, tighten all the screws holding the hinge.
15. Stand the unit back in the upright position.

TEMPERATURE CONTROL

The refrigerator temperature can be regulated by adjusting the FRIDGE CONTROL. The refrigerator temperature is the lowest when the FRIDGE CONTROL is set to "COLDEST".

The refrigerator temperature will vary depending on the quantity of the food stored and on the frequency with which the door is opened. Set the FRIDGE CONTROL to the "COLDEST" position only when ice cubes are needed in a hurry.

This refrigerator may turn on and off more frequently than regular size refrigerators. This is normal due to its compact size.

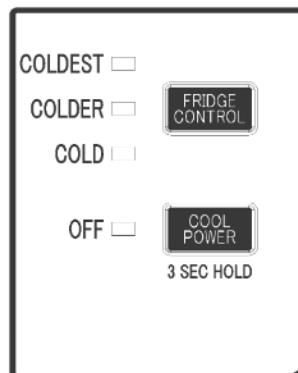

Cool Power Off

- When the COOL POWER button is pressed for three (3) seconds or more, the OFF-LED light turns on, and the refrigerator stops operating.
- When the COOL POWER button is pressed for three (3) seconds or more again, the OFF-LED light turns off, and the refrigerator resumes operation.

NOTE: If operation is stopped using the COOL POWER button, as described above, allow at least five (5) minutes before restarting in order to allow the start relay to function properly.

REMOVING CUBES FROM THE ICE TRAY

- The ice cube tray is flexible. Twist the tray to remove ice cubes.
- Do not use boiling water or a metal instrument such as a knife or screw driver to remove ice cubes from the tray. This may damage plastic parts.

CLEANING AND CARE

- Turn off the refrigerator and remove foods, shelves, trays, etc. Wash the interior liner with a solution of warm water and two tablespoonfuls of baking soda per quart. Then rinse and wipe. Do not use soaps, detergents, scouring powder, spray cleaners or the like on the liner, as these may cause odors in the refrigerator compartment.
- Wash THE ice cube tray, drip trays and shelves in a mild detergent solution and dry with a soft cloth.
- Wipe the exterior surface with a soft cloth dampened with soapy water and then dry with a soft cloth. A spray appliance cleaner may be used for the exterior only.
- Use only lukewarm soapy water to clean the door gaskets.
- Never use acids, chemical thinner, gasoline, benzene or the like for cleaning any part of the refrigerator. Boiling water and benzene may deform or damage plastic parts.

Vacation Time

- **Short vacations:** Leave the unit operating during vacations of less than three weeks.
- **Long vacations:** If the appliance will not be used for several months, remove all food and unplug the power cord. Clean and dry the interior thoroughly. To prevent odor and mold growth, leave the doors open slightly, blocking them open if necessary.

Moving Your Refrigerator

1. Remove all the food.
2. Securely tape down all loose items inside your refrigerator.
3. Tape the door shut.
4. Be sure the refrigerator stays secure in the upright position during transportation. Also protect the outside of the refrigerator with a blanket or similar item.

TROUBLESHOOTING

You can solve many common freezer problems easily, saving you the cost of a possible service call. Try the suggestions below to see if you can solve the problem before calling the servicer.

PROBLEM	POSSIBLE CAUSE
The appliance does not operate.	The unit is not plugged in The circuit breaker has tripped, or a fuse has blown. The appliance temperature control is set at "OFF".
The appliance turns on and off frequently.	The room temperature is warmer than normal. A large number of items have been added to the appliance. The door is opened too often. The door is not closed completely. The temperature control is not set correctly. The door gasket does not seal properly. The appliance does not have the correct clearances.
Vibrations	Check to be sure the appliance is level.
The appliance seems to make too much noise.	A rattling noise may come from the flow of the refrigerant, which is normal. As each cycle ends, you may hear gurgling sounds caused by the flow of refrigerant in your appliance. Contraction and expansion of the inside walls may cause popping and crackling noises. The appliance is not level.
The door will not close properly.	The appliance is not level. The door was reversed and not properly installed. The gasket is dirty. Shelves, bins, or baskets are out of position.

If your appliance shows other symptoms than those described above, or if you have checked all items listed as the cause and the problem still exists, then call SUMMIT® Customer Service at **1-800-932-4267**.

NOTES

LIMITED WARRANTY

ONE-YEAR LIMITED WARRANTY

Within the 48 contiguous United States, for one year from the date of purchase, when this unit is operated and maintained according to instructions attached to or furnished with the product, warrantor will pay for factory-specified parts and repair labor to correct defects in materials or workmanship. Service must be provided by a designated service company. Outside the 48 states, all parts are warranted for two years from manufacturing defects. Plastic parts, shelves and cabinets are warranted to be manufactured to commercially acceptable standards and are not covered from damage during handling or breakage.

FIVE-YEAR COMPRESSOR WARRANTY

1. The compressor is covered for five years.
2. Replacement does not include labor.

ITEMS WARRANTOR WILL NOT PAY FOR:

1. Service calls to correct the installation of your equipment, to instruct you how to use your equipment, to replace or repair fuses or to correct wiring or plumbing.
2. Service calls to repair or replace unit light bulbs or broken shelves. Consumable parts (such as filters) are excluded from warranty coverage.
3. Damage resulting from accident, alteration, misuse, abuse, fire, flood, acts of God, improper installation, installation not in accordance with electrical or plumbing codes, or use of products not approved by warrantor.
4. Replacement parts or repair labor costs for units operated outside the United States.
5. Repairs to parts or systems resulting from unauthorized modifications made to the unit.
6. The removal and reinstallation of your unit if it is installed in an inaccessible location or is not installed in accordance with published installation instructions.

DISCLAIMER OF IMPLIED WARRANTIES; LIMITATION OF REMEDIES

CUSTOMER'S SOLE AND EXCLUSIVE REMEDY UNDER THIS LIMITED WARRANTY SHALL BE PRODUCT REPAIR AS PROVIDED HEREIN. IMPLIED WARRANTIES, INCLUDING WARRANTIES OF MERCHANTABILITY OR FITNESS FOR A PARTICULAR PURPOSE, ARE LIMITED TO ONE YEAR. WARRANTOR SHALL NOT BE LIABLE FOR INCIDENTAL OR CONSEQUENTIAL DAMAGES. SOME STATES DO NOT ALLOW THE EXCLUSION OR LIMITATION OF INCIDENTAL OR CONSEQUENTIAL DAMAGES, OR LIMITATIONS ON THE DURATION OF IMPLIED WARRANTIES OF MERCHANTABILITY OR FITNESS, SO THESE EXCLUSIONS OR LIMITATIONS MAY NOT APPLY TO YOU. THIS WARRANTY GIVES YOU SPECIFIC LEGAL RIGHTS AND YOU MAY ALSO HAVE OTHER RIGHTS, WHICH VARY FROM STATE TO STATE.



WARNING: This product can expose you to chemicals including Nickel (Metallic) which is known to the State of California to cause cancer.

For more information go to www.P65Warnings.ca.gov

Note: Nickel is a component in all stainless steel and some other metallic compositions.

Felix Storch, Inc.
An ISO 9001:2015 registered company
770 Garrison Ave
Bronx, New York 10474
www.summitappliance.com

SUMMIT
For parts and accessory ordering,
troubleshooting and helpful hints, visit:
www.summitappliance.com/support

LLF2 Combination Cam Lock Instructions



LLF2 combination lock installed

I. Manufacturer's combination

The manufacturer has set the combination code at 0-0-0-0.

II. Resetting the combination

- Make sure the digit wheels are set at the correct code so that the housing turns freely. The cam should be engaged so that the doors of the appliance cannot open.
- Use a screwdriver or other tool to push down and hold the reset button until you have entered your new code. (Fig. 1)
- Turn the four digit wheels to your new combination code, then release the reset button.
- Make sure the housing is able to turn freely at the new setting. Code setting is complete.

III. To lock

While the lock is in the unlocked position (i.e., the housing can be turned by hand), randomly set the digit wheels to lock. (Fig. 2)

IV. To unlock

Turn the digit wheels to the correct code to unlock. (Fig. 3)

V. Use key to unlock

You can use the key to unlock if you forget the combination.

- Insert key into the barrel. (Fig. 4)
- Turn the key 90 degrees to unlock. If the key is used to unlock, the cam will also turn 90 degrees when the key is rotated. However, the digit wheels will not rotate.

