



www.santos.fr

CITRUS JUICER #52

For all citrus fruits: limes, lemons, oranges, grapefruits.
High output model



Internationally patented models





POWERFUL, EFFICIENT, DURABLE

The citrus juicer #52 is the perfect appliance to squeeze any kind of citrus thanks to the 3 removable squeezers (cones) delivered with the juicer.

This commercial juicer is equipped with powerful and reliable commercial motor.

For use everywhere you need a fresh squeezed citrus juice: juice bars, health food stores, hotels, bars, restaurants, cafeterias, ice cream shops, institutions and hospitals...

High output: just cut your citrus half and press. You will extract easily from 20 to 40 liters per hour (5 to 10 gallons).

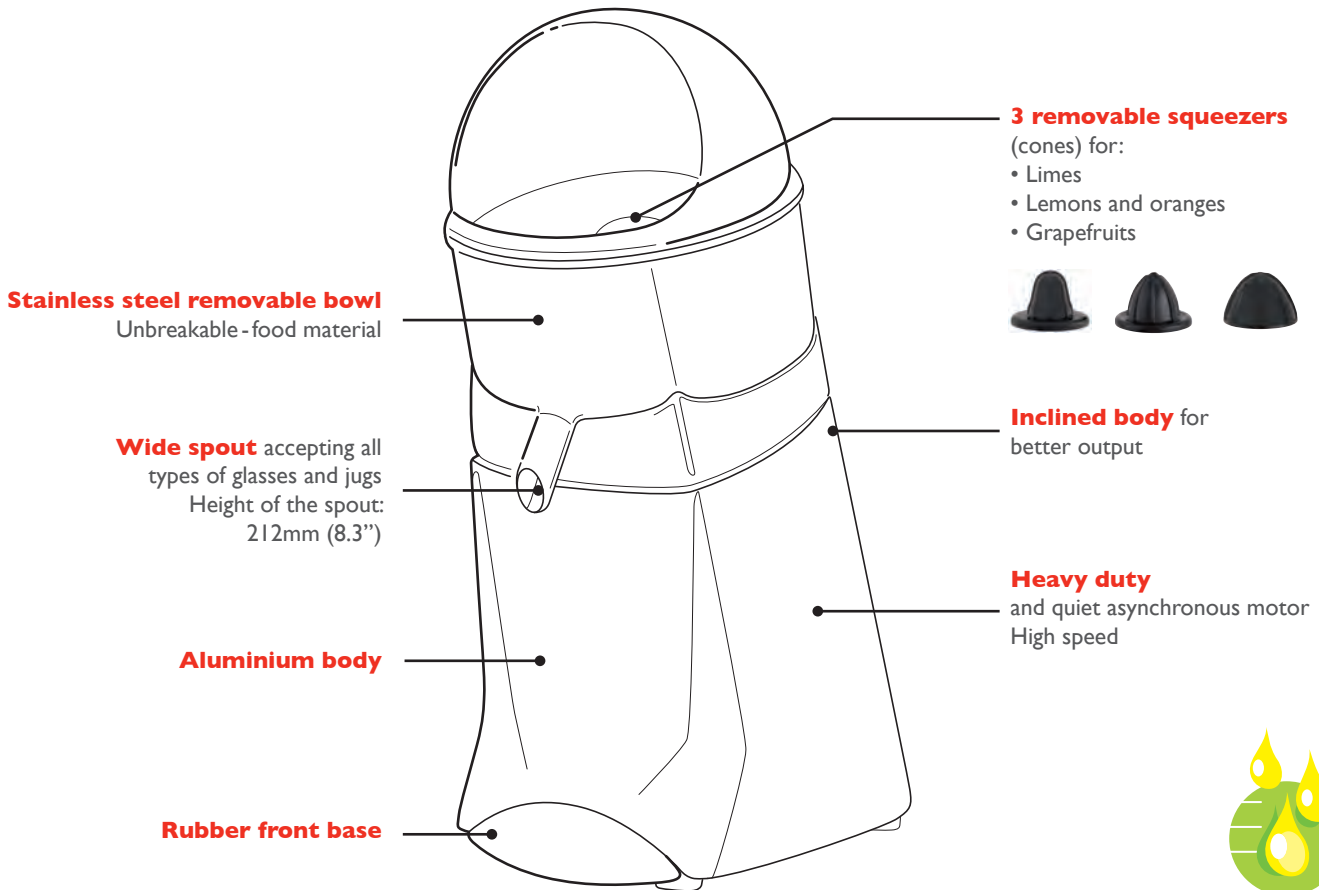

Output up to 40 l/h

THE COMPLETE RANGE OF THE CITRUS JUICER #52



52C



52G

CHOOSE

YOUR COLOUR!

CITRUS JUICER #52



EASY TO USE - EASY TO CLEAN - COMPLETELY SAFE

www.santos.fr



The unique juicer that you can clean quickly and easily: just wash the main different parts of the top. All these parts are easily removable from the base in a simple movement.



TECHNICAL SPECIFICATIONS



Motor

Single phase: 100 - 120V - 50/60 Hz - 260 W - CE, UL, NSF
220-240V - 50/60Hz - 230W - CE, KC

Speed: I 500 rpm (50 Hz)
I 800 rpm (60 Hz)



Weight

Net: 9,5 Kg (21 lbs)
Packed: 10,5 Kg (23 lbs)

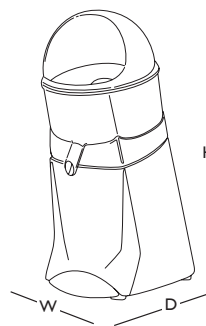

APPLIANCE

W: 205mm / 8"
D: 305mm / 12"
H: 490mm / 19"

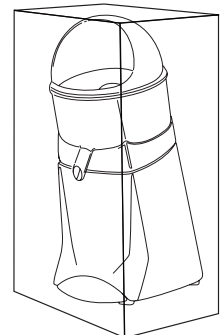

SHIPPING BOX

W: 250mm / 9,8"
D: 300mm / 11,8"
H: 585mm / 23"

SAFETY - STANDARDS - HYGIENE

In accordance with the following regulations:

Machinery directive 2006/42/EC
Electromagnetic compatibility 2004/108/EC
RoHS directive 2002/95/EC
"Low voltage" Directive 2006/95/EC
Regulation 1935/2004/EC (contact with food)

Harmonized European standards

EN 12100-1 and 2: 2004 - EN 60204-1: 2006
EN 60335-2-64: 2004 Commercial electric kitchen machines

CE (European standards),
NSF (USA), UL (USA) and cUL (Canada), KC (Korea)

Electrical safety

- On/Off interlock switch is waterproof
- All mechanical parts are ground (earth) connected
- All equipment is 100% tested at the end of assembly (special electrical testing bay)

Thermal safety

Motor protected by internal thermal detector.

Acoustic safety

The asynchronous motor with direct driving is particularly silent.

Hygiene

All removable parts can be put in a dishwasher or easily cleaned with hot soapy water (NSF approved).

PRODUCT: 2-YEAR WARRANTY | MOTOR: 5-YEAR WARRANTY

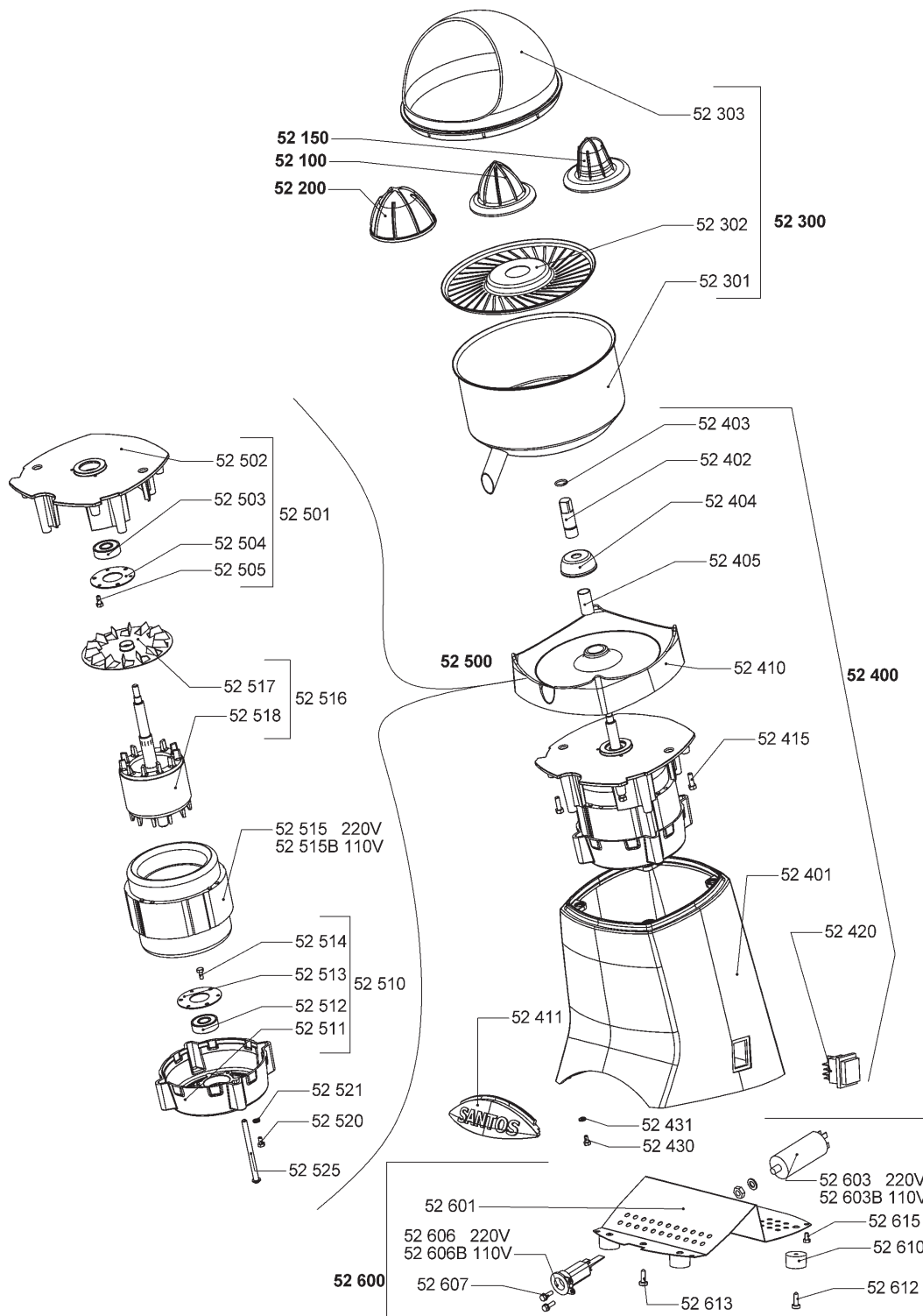

SANTOS

140-150 Avenue Roger Salengro BP 80 067 – 69511 Vaulx-en-velin Cedex (Lyon) – FRANCE
 Tel. +33 4 72 37 35 29 – Fax. +33 4 78 26 58 21 – Website: www.santos.fr – Email: santos@santos.fr

Follow us on #SantosAddict social networks   