



www.santos.fr

**KITCHEN BLENDER
SANTOSAFE® #37**



**New
version**

NEW DESIGN
PERFECT BLENDING
MORE POWERFUL

Internationally patented models





KITCHEN BLENDER

SANTOS KNOW-HOW IN YOUR KITCHEN

The kitchen blender #37 is the ideal appliance for mixing, liquefying, grinding, crushing... to make all kinds of hot and cold preparations: gazpachos, soups, purées, creams...

It quickly crushes hard ingredients (ice cubes, lobster carcass...).

Ideal for restaurants, institutions, hospitals, child care centers, hotels and ice-cream shops.

Exclusive patent:
Santosafe® locking system
for bowl and cover. Hands free use.
In conformity with the professional European Standards
for a completely safe use.

2L (68 oz) or 4L (136 oz) bowls,
stainless steel or transparent
(without bisphenol A)
adaptable to the same base.

New blades, high resistance,
offering a **high quality blending**
and a **better vortex**.
Knife assembly is ball bearings mounted.

On/Off rotary button.
Variable speed:
from 0 to 15000rpm

Handle to open and close
Santosafe® locking system

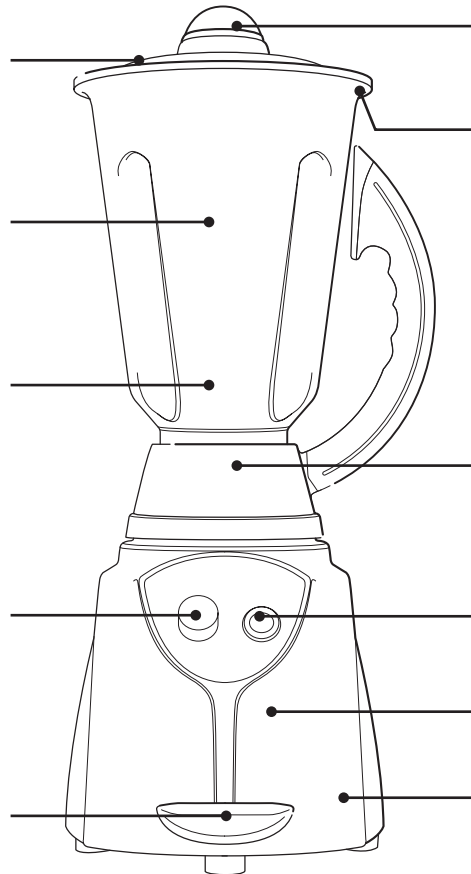

Removable lid to add ingredients while blending (Ø46 mm / 1.8")

New waterproof removable rubber seal equipped with a tab (easy opening of the cover).
Resists high temperatures and frequent cleaning.

Silent and durable coupling system kit for **intensive use**

New pulse: 18000rpm

New powerful and reliable commercial motor. Excellent energy efficiency.

Painted aluminium base

A COMPLETE RANGE OF BOWLS FOR ALL USES



CHOOSE YOUR BOWL



2L



2P



4L



4P

SANTOSAFE® #37



QUALITY BLENDER

www.santos.fr

Powerful and efficient

- Powerful commercial motor, very silent.
- New blades, highly resistant, for a maximum efficiency on all kinds of preparations (liquids and solids).
- Speed variation from 0 to 15000rpm and pulse: 18000rpm.

Safe

- Exclusive patent: Santosafe® locking system for bowl and cover. The motor stops when opening the locking system.
- 2L (68oz) or 4L (136oz) bowls, stainless steel or transparent (without bisphenol A)
- Removable lid to safely add ingredients while blending

Easy to use

- Hands free use thanks to the locking system for bowl and cover.
- Possibility to add ingredients while blending thanks to the filler cap on the cover.
- Easy cleaning: removable bowl, blade, cover and cover seal.

Choose the speed according to your preparations

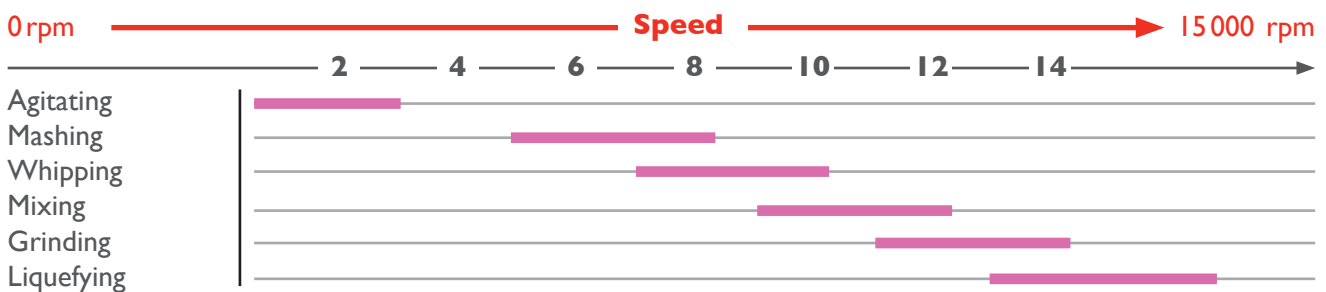

TECHNICAL SPECIFICATIONS



Motor

Single phase: 220-240V – 50/60 Hz – CE

Max input power : 1550W

Max output power : 1200W

Speed: from 0 to 18000rpm (50Hz/60Hz)



Weight

Net: 11 kg (24lbs)

Shipping: 13 kg (28.5 lbs)



APPLIANCE

D: 303 mm (12")

W: 220 mm (8.6")

H: 566 mm (22")



SHIPPING BOX (BASE)

D: 390 mm (15.4")

W: 275 mm (10.8")

H: 650 mm (25.6")



SHIPPING BOX (BOWL)

D: 240 mm (9.4")

W: 360 mm (14.2")

H: 220 mm (8.6")

SAFETY, STANDARDS, HYGIENE

In accordance with the following regulations

- Machinery directive 2006/42/EC
- Electromagnetic compatibility 2004/108/EC
- "Low voltage" Directive 2006/95/EC
- RoHS directive 2002/95/EC
- Regulation 1935/2004/EC (contact with food)
- EN 12852 + A1: 2010 Food processors and blenders, safety and hygiene requirements

Harmonized European standards

EN ISO 12100 - 1 and 2: 2004

EN 60204-1: 2006

CE (Europe)

Electrical safety

- All mechanical parts are ground connected.
- Appliances are 100% tested after assembly.

Thermal safety

Motor protected by internal thermal detector

Acoustic safety

Silent and powerful motor

Hygiene

All removable parts can be put in a dishwasher or easily cleaned with hot soapy water.

PRODUCT: 2-YEAR WARRANTY

KITCHEN BLENDER SANTOSAFE® #37



www.santos.fr

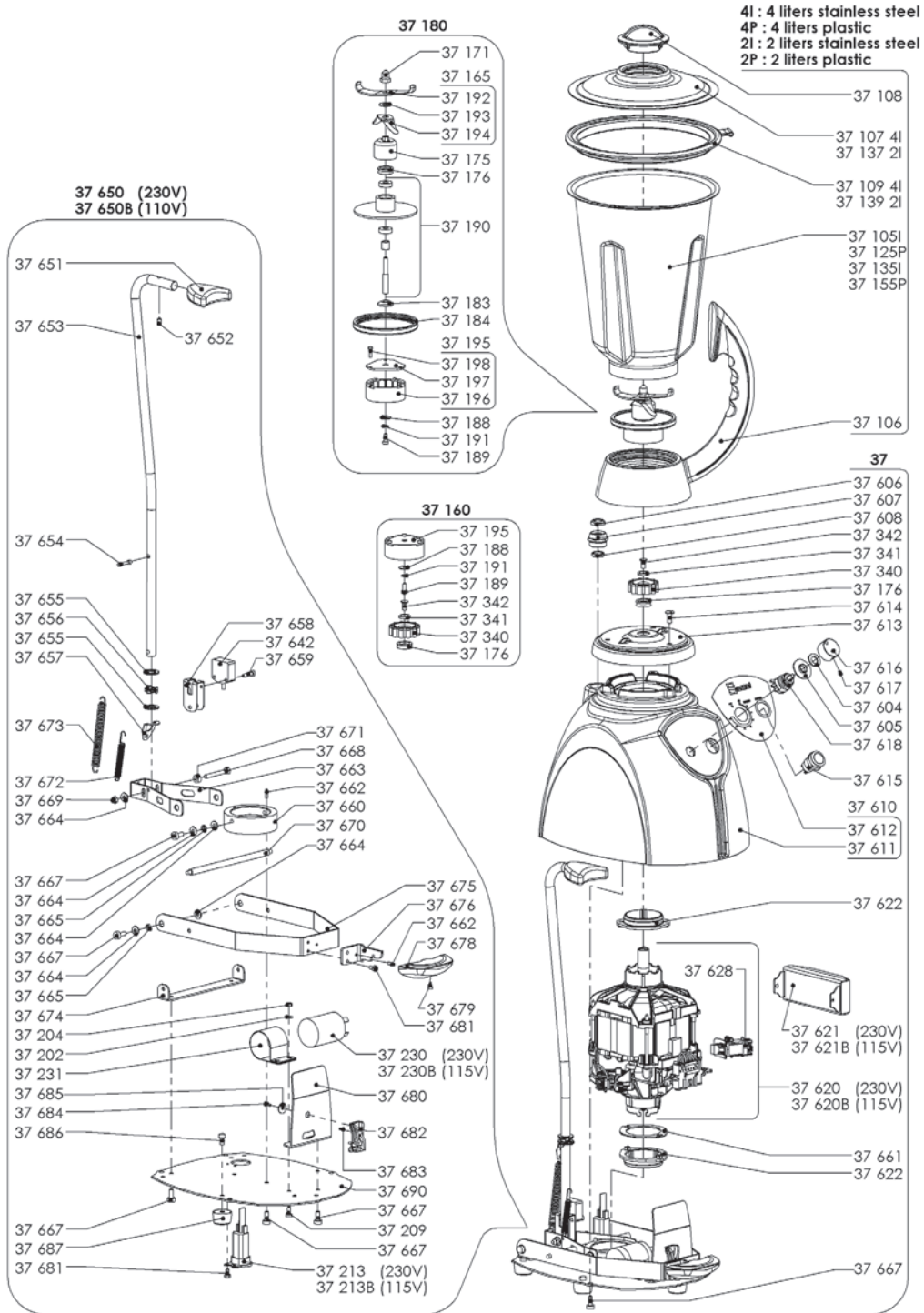

SANTOS

140-150 Avenue Roger Salengro – 69120 VAULX-EN-VELIN (Lyon) – FRANCE – TEL. +33 472 37 35 29 – FAX. +33 478 26 58 21

Website: www.santos.fr – **Email:** santos@santos.fr