

SICO[®] Sophisticate Plus

Style, mobility, and durability with induction cooking or warming in one upscale table.



Features, Advantages & Benefits

Induction Units - These warming and cooking units are more energy efficient, cleaner, and cost effective than gas or electric units.

Advanced Electronic Temperature Controls - Controls are streamlined, attractive and easy-to-use.

Folding Table Top

- **Top folds & nests** for efficient storage using up less facility space when not in use.
- **NSF Certified Natural Stone Composite Top**
 - Completely sealed top surface is durable and easy-to-clean.
 - Superior scratch and stain resistant. Cut directly on the table surface.
 - Set hot items up to 500° directly on the NSF certified surface material without scalding.
 - Exquisite top color choices. An elegant and refined high-end table.
 - Durable .25" (.6cm) natural stone composite top made of 95% natural stone and 5% Polymer formed over .75" (2cm) MDF.
- **High-pressure Laminate**
 - Tough surface for added durability and long-term wear.
 - Sanitary and easy-to-clean.
 - A large variety of striking colors and patterns are available to fit any color scheme.

Table Frame

- **Oval Tubular Understructure** – 16 gauge oval tubular frame understructure adds style and strength to the table.
- **Double Cross Member Construction** - Adds strength & longevity.

Black Powder-coat Finish - Durable understructure with elegant baked-on surface.

Pneumatic Dampers - Makes folding the tabletop quick and easy.

Mobile Dual-wheel Casters - Easily roll table into and out of service for any function. Non-marring, 4" (10cm) caster wheels protect floors.

Free Space Analysis - Take advantage of the free space analysis drawings which will provide you with the appropriate number of tables and table accessories.

Warranty – Comes with a 3-Year Warranty on the mechanism. Lifetime Warranty on welds. Induction units protected by a **1 Year Warranty**.

Specifications

Description	Model No.	Table Top	Table Height	Weight
1 Cooking Unit Table	RBF11NPG??C?4?	32" (82cm) W 72" (183cm) L.	36" (91cm).	305 lbs
2 Cooking Unit Table	RBF11NPG??C?1?	32" (82cm) W 72" (183cm) L.	36" (91cm).	315 lbs
1 Warming Unit Table	RBF11NPG??W?4?	32" (82cm) W 72" (183cm) L.	36" (91cm).	305 lbs
2 Warming Unit Table	RBF11NPG??W?1?	32" (82cm) W 72" (183cm) L.	36" (91cm).	315 lbs
3 Warming Unit Table	RBF11NPG??W?5?	32" (82cm) W 72" (183cm) L.	36" (91cm).	325 lbs

* Custom Natural Stone Composite choices available.

Units Configured With

SICO offers FIVE standard choices.

Each tabletop may be equipped with 1 or 2 induction cooking units or 1,2 or 3 induction warming units.
For any other configuration please consult a SICO sales representative at 1.800.328.6138.

Induction Warming Unit

Warming Temperature Ranges:

130°F / 54°C
140°F / 60°C
160°F / 71°C
175°F / 79°C
200°F / 93°C

Domestic 120VAC Power Requirements

- Load Per Unit: (400 watts) - 4 Amps.
- (1) 15 Amp surge protector with single US 15A power cord.

Domestic 240VAC Power Requirements

- Load Per Unit: (400 watts) - 2 Amps.
- (1) 15 Amp surge protector with single US 240V power cord.

Induction Cooking Unit

Cooking Temperature Ranges:

95°F / 35°C
125°F / 52°C
175°F / 79°C
250°F / 121°C
300°F / 148°C
350°F / 177°C
400°F / 204°C
450°F / 232°C

Domestic 120VAC Power Requirements

- Load Per Unit: (1800 watts) - 15 Amps.
- (1) 15 Amp power cords requiring dedicated circuit per each induction unit.

Domestic 240VAC Power Requirements

- Load Per Unit: (1800 watts) - 7.5 Amps.
- (1) 15 Amp surge protector with single US 240V power cord.

Natural Stone Composite Top Options



Nero Galaxy (60)



Karra Oro (62)



Sachi (64)



Bianco Modena (67)

Table Leg Frame Options



Black (B)



Copper Vein (R)



Silver Vein (L)



For More Information Visit: <http://www.sicoinc.com/sophisticateplus.php>
7525 Cahill Road, Minneapolis MN 55439
1.800.533.7426

SICO[®] Sophisticate Plus Table Dimensions

Dimensions

Top Height: 36" Folded Height: 47" Table Top Size: 32x72"

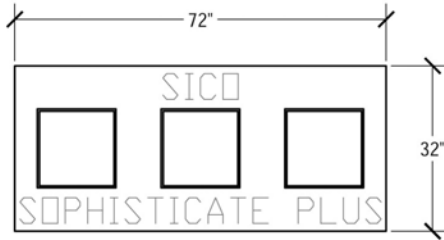
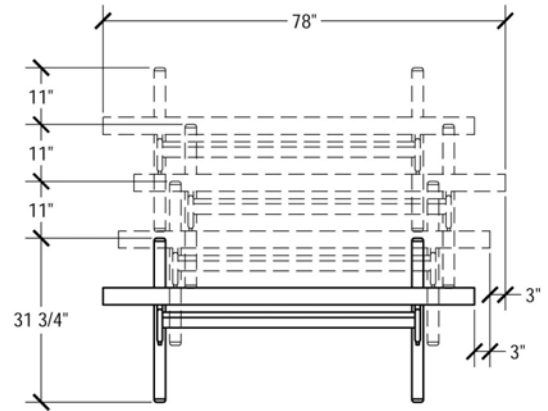

Table Dimensions



Storage Configuration



For More Information Visit: <http://www.sicoinc.com/sophisticate.php>

7525 Cahill Road, Minneapolis MN 55439

1.800.533.7426