



Job: _____

Item No. _____

DESIGNED FOR HIGHER VOLUME APPLICATIONS

Seven – 4 oz. Servings per Minute per side and 17 Quart Capacity per side

IDEAL FOR SELF-SERV BUFFETS, CAFETERIAS, QUICK SERVICE RESTAURANTS

The **Saniserv**® model 522 Soft Serve Freezer provides the highest volume of two individual flavors as well as a flavor twist. The 522 offers the highest volume of high profit, consistent quality soft serve and yogurt products in the **SaniServ**® product lineup. Two large independent flavor product reservoirs and barrels guarantee separation of product and flavors. Large product capacity and quick recovery time insure customers receive their favorite flavors individually or with a twist!

NEW SCROLL COMPRESSOR

Provides the **SaniServ**® Model 522 with quieter operation. It is 20% more efficient. Increased durability, with 50% longer service life.

SPACE MAXIMIZING

Traditional Floor Model Design - SaniServ® model 522 turns valuable floor space into a real profit center by serving the highest volume of two high profit soft serve and frozen yogurt.

EASY CLEANING AND OPERATION

Fewer Parts = Simplified Cleaning – SaniServ® equipment is designed and built with the fewest parts to be disassembled, cleaned and sanitized than any other machine in the industry. The state of the art solid-state **Touch AccuFreeze**™ control insures product consistency, worry-free operation and customer satisfaction.

HIGH RETURN ON INVESTMENT

Increased Profits – SaniServ® machines combine efficiency with consistent product quality and fast, quiet operation while insuring customer satisfaction with high profit ice cream or yogurt products.

QUALITY DESIGN

Durability – SaniServ® machines are built to achieve long and dependable life through simplicity of design. Every machine is shipped standard with a stainless steel exterior, durable steel interior frame construction, heavy-duty components and consistency systems.

Model 522

Floor Model

**Twist Soft Serve
Ice Cream / Yogurt Machine
With AccuFreeze™ Control**



Made in USA

We reserve the right to change specifications and product designs without notice. Such revisions do not entitle the buyer to corresponding changes, improvements, additions or replacements for previously purchased equipment.

MODEL 522

Floor Model *Twist* Soft Serve/Yogurt Freezer

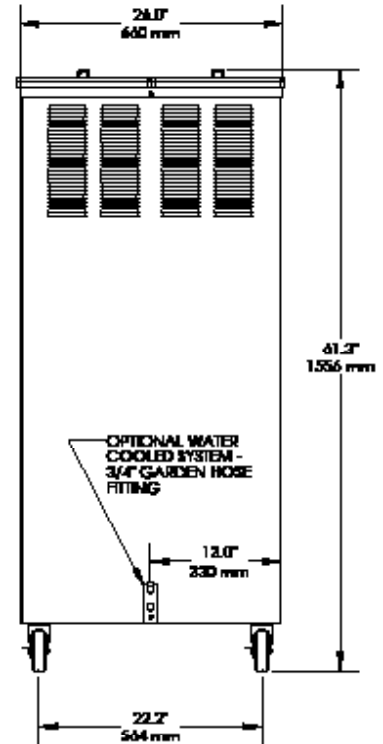
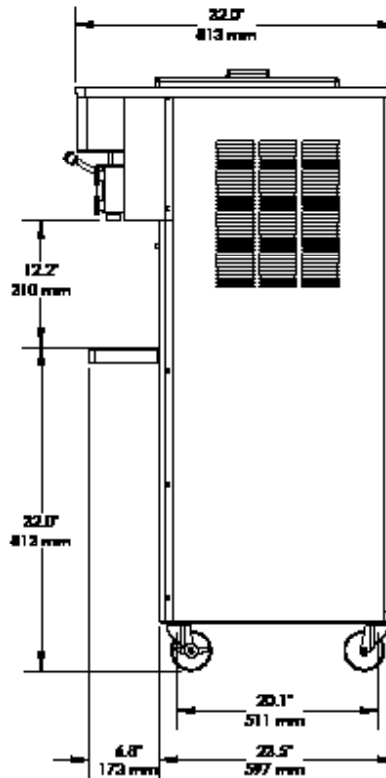
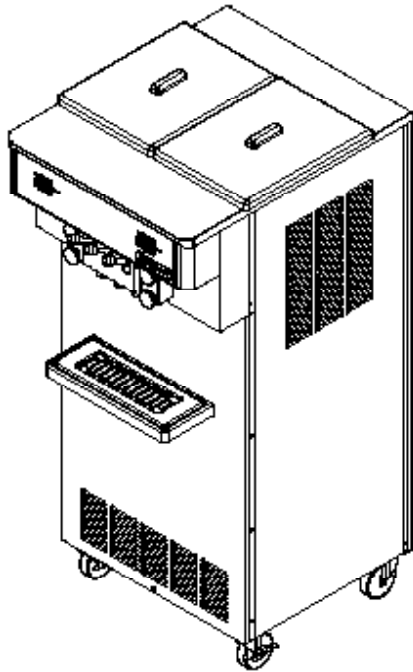

Minimum Wall Clearance
Both Sides and Back -
6 inches (152 mm)

ELECTRICAL				WIDTH	HEIGHT	DEPTH	WEIGHT	VOLUME
VOLTS	Hz	Ph.	Amps	INCHES (MM)	INCHES (MM)	INCHES (MM)	LBS. (Kg)	CU FT. (cu. m.)
208-230	60	1	30*	26 (660)	59.5 (1511)	30 (762)	603 (274)	
208-230	60	3	20*					
Shipping Specifications				36 (914)	65 (1650)	40 (1016)	675 (306)	54.8 (1.53)

* Two separate circuits required.

Specifications:

Cooling System:

Air or Water

Dasher and Compressor Motors:

- (2) 1 HP Dashers
- (2) 2 HP Scroll Compressor

Refrigerant Type:

R404A

Listings:

UL, cUL, NSF

Features:

Evaporator and Mix Reservoir

Capacity:

17 Quarts (16.15 liters) per side

Dasher:

Heavy-Duty Stainless Steel with low friction scraper blades.

Controls:

Touch AccuFreeze™ solid-state control for accurate product consistency.

Solid State Audio/Visual Mix Out System with Compressor Lockout

Warranty:

Parts 1 year
Compressor 5 years
Evaporator 5 years

Options:

- Tune Up Kit
- Parts Tray
- Syrup Rail
- Water Cooled - 3/4" Garden Hose Fitting
- Wash Out Kit - 3/8" Flare Fitting
- Export Voltages

451 E. County Line Rd. • P.O. Box 1089 • Mooresville, IN 46158
Toll Free 800-733-8073 • Local 317-831-7030 • Fax 317-831-7036

www.saniserv.com

REV 07-2015