

➤ **2" H x 4" W Aluminum Slides**

Welded to Frame

➤ **Holds**

22" x 26 7/8" Oval Trays

➤ **Heavy-Duty 5" Swivel Stem Casters (CHV)**

300 lb. Capacity Per Caster

➤ **All Aluminum – Will Not Rust**

Ships LTL

➤ **Optional**

Heavy-Duty Locking Casters (CHL)
Pan Stop (PS)

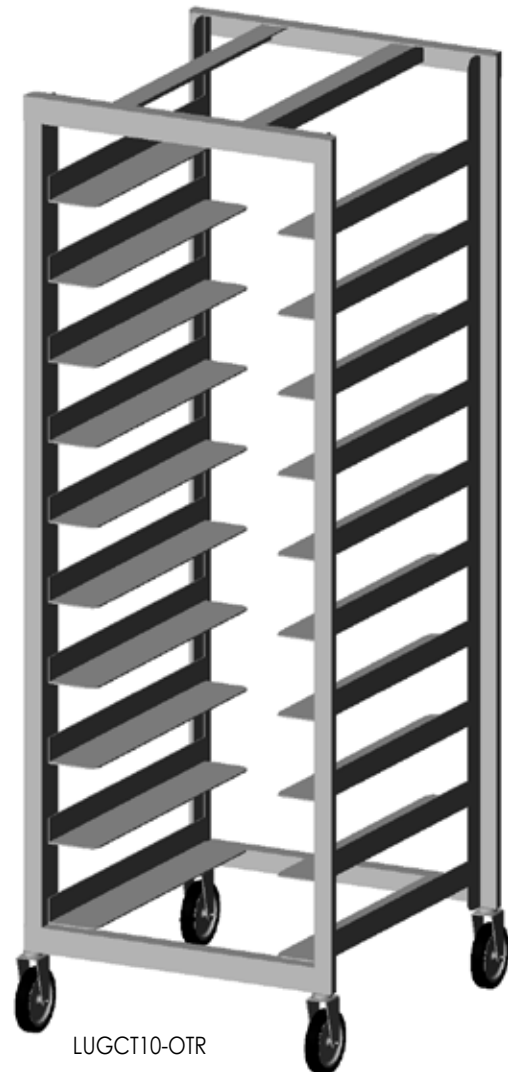
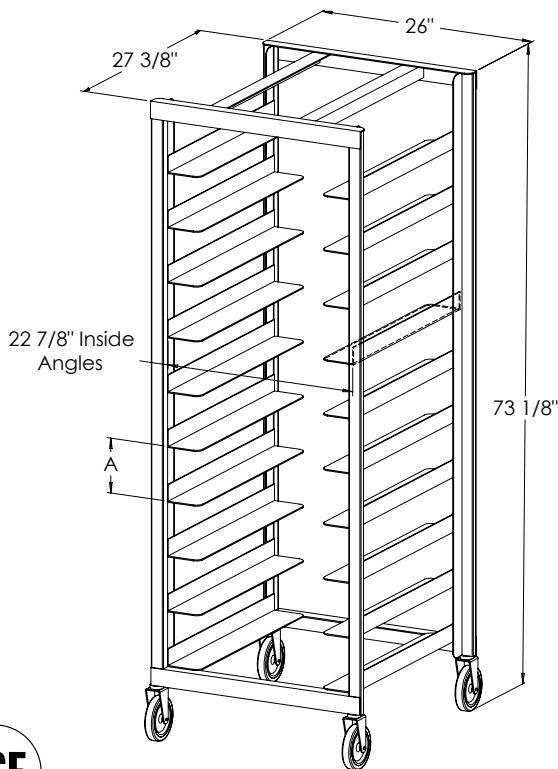

Oval Tray Racks		
Model Number	Tray Capacity	"A" Shelf Spacing
LUGCT12-OTR	12	5"
LUGCT10-OTR	10	6"

Options: "CHL", "PS" - see page 77 for details.