



# REFRIGERATION

SERVING THE FOOD INDUSTRY SINCE 1951

## 53-INCH 2-DOOR SLIDING GLASS REFRIGERATOR

Item: 50032 Model: RE-CN-0045-HC



### THE PERFECT SOLUTION TO EXHIBIT COLD MERCHANDISE

Omcan's 53-inch 2-door sliding glass refrigerator is perfect for your products, with the outside material made from painted steel. Its crystal clear, self closing door is perfect to see the products inside. It also features automatic defrosting and high density polyurethane insulation. Energy Certified.



### WARRANTY

2 YEARS PARTS & LABOR  
5 YEARS ONLY ON COMPRESSOR

NEMA  
5 - 15  
125 VAC / 15 AMP



Authorized Dealer

# REFRIGERATION

53-INCH 2-DOOR SLIDING GLASS REFRIGERATOR 50032



## TECHNICAL SPECIFICATION

|                           |                                              |
|---------------------------|----------------------------------------------|
| ITEM NUMBER               | 50032                                        |
| MODEL                     | RE-CN-0045-HC                                |
| DESCRIPTION               | 2-Door Sliding Glass Refrigerator            |
| TEMPERATURE RANGE         | 0°C - 5°C / 33°F - 41°F                      |
| MAX AMBIENT TEMP RATING   | 90°F                                         |
| POWER                     | 0.25+                                        |
| PHASE                     | 1                                            |
| ELECTRICAL                | 110V/60Hz/1Ph                                |
| AMPS                      | 4.3                                          |
| REFRIGERANT               | R290                                         |
| COOLING SYSTEM            | Ventilated                                   |
| NUMBER OF DOORS           | 2                                            |
| NUMBER OF SHELVES         | 8                                            |
| NET VOLUME                | 45 cu.ft. / 1270 liters                      |
| SHELF CAPACITY            | 90 lbs. / 41 kg.                             |
| EXTERIOR DIMENSIONS (WDH) | 53.25" x 32" x 83.8"<br>1353 x 813 x 2129 mm |
| INTERIOR DIMENSIONS (WDH) | 50" x 28.25" x 62"<br>1270 x 718 x 1575 mm   |
| PACKAGING DIMENSIONS      | 56.3" x 33.46" x 84"<br>1430 x 850 x 2134 mm |
| NET WEIGHT                | 441 lbs. / 200 kg.                           |
| GROSS WEIGHT              | 496 lbs. / 225 kg.                           |



## Features:

- Outside material: Painted steel
- Self-closing doors
- Plastic coated steel shelves with shelf tag holder
- Automatic defrosting
- Polyurethane insulation
- Removable door gasket
- Removable installation board for easy maintenance
- Shelf Capacity: 90 lbs. / 41 kg.
- Temperature range: 0°C - 5°C / 33°F - 41°F

## TECHNICAL DRAWING AND DIMENSIONS

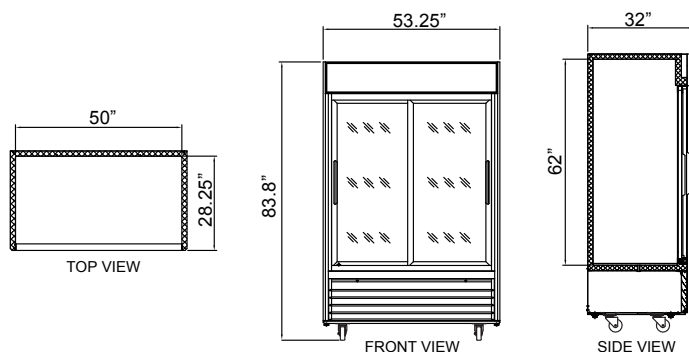

NEMA  
5 - 15  
125 VAC / 15 AMP



## OMCAN INC.

Telephone: 1-800-465-0234

Fax: (905) 607-0234

Email: sales@omcan.com

Website: www.omcan.com



Follow us to keep up to date with the latest news and offers



2017E&OE