



FOOD WARMER

SERVING THE FOOD INDUSTRY SINCE 1951

COUNTERTOP FOOD WARMER 3.5 QT. CAPACITY

Item: 44310

Model: FW-CN-0004

Your favourite toppings at the perfect temperature!



Omcan's countertop stainless steel food warmer is perfect for snack bars, concession stands, cafeterias, buffet lines, and a wide variety of other applications. This compact product features an adjustable thermostat, excellent for cheese, fudge, caramel, gravy and chili. Serve your favourite toppings at the perfect temperature any time of day!



WARRANTY
PARTS AND LABOR

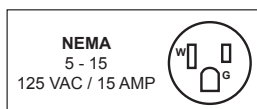

Authorized Dealer

FOOD WARMER

COUNTERTOP FOOD WARMER

3.5 QT. Capacity



Features:

- Stainless steel interior and exterior fitting a 3.5 QT inner pot, lid and ladle accessories
- The temperature control has 6 settings to provide you with heat flexibility, maximum heat is 95° C / 203° F
- Manually wash product for thorough cleaning
- Perfect for keeping your most popular toppings or condiments hot and ready to serve!
- 500 Watts provides quick and easy heating
- 4.2 amp heater requires a 120 V electrical connection which comes ready to use with a durable power chord

TECHNICAL SPECIFICATION

| | |
|----------------------|---|
| ITEM NUMBER | 44310 |
| MODEL | FW-CN-0004 |
| DESCRIPTION | Countertop stainless steel food warmer |
| CAPACITY | 4.4 L / 3.5 QT |
| POWER | 500 W |
| ELECTRICAL | 120 V / 60 Hz / 1 Ph |
| WEIGHT | 8.15 lbs. |
| PACKAGING WEIGHT | 10.14 lbs. |
| DIMENSIONS (WDH) | 9.1" x 11.8" x 11.3" / 231 mm x 300 mm x 287 mm |
| PACKAGING DIMENSIONS | 11.8" x 19.29" x 15.4" / 300 mm x 490 mm x 391 mm |

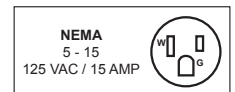
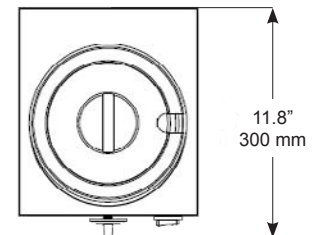
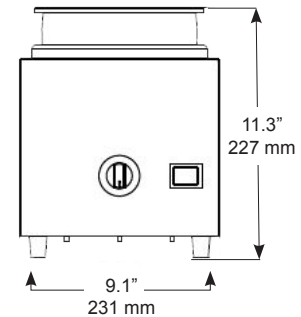

OMCAN INC.

Telephone: 1-800-465-0234
 Fax: (905) 607-0234
 Email: sales@omcan.com
 Website: www.omcan.com



Follow us to keep up to date with the latest news and offers

