



CUSTOMER CONVENIENCE

SERVING THE FOOD INDUSTRY SINCE 1951

## 36-GALLON TRASH RECEPTACLE

Item: 43840

*Omcan's trash receptacle with swing door provides the excellent compact solution for waste management. It is the perfect companion for restaurants, healthcare facilities, schools, offices, and hotels. Features an engraved message to reiterate the gratitude towards your customers as well as a recessed top for discarded food trays.*



Authorized Dealer

## FEATURES:

- Fits Standard 36 gallon / 3.78 litres bin
- Laminated melamine
- Hinged opening with engraved “thank you” message
- Food tray holder on top area
- Swing door for ease of cleaning

## TECHNICAL SPECIFICATION

ITEM NUMBER	43840
MATERIAL	plywood / melamine
COLOR	Natural
NET WEIGHT	43KGS / 94.80 LBS
GROSS WEIGHT	45KGS / 99.20 LBS
DIMENSIONS (DWH)	22" x 47" x 22" / 558.80mm x 1193.80 x 558.80mm
PACKAGING DIMENSIONS	47" x 22" x 4.72" / 1200X570X120mm

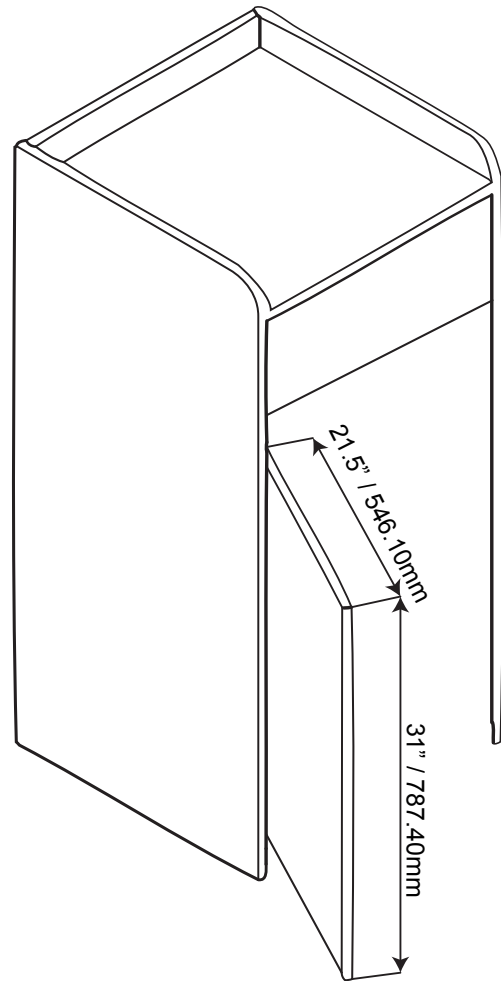
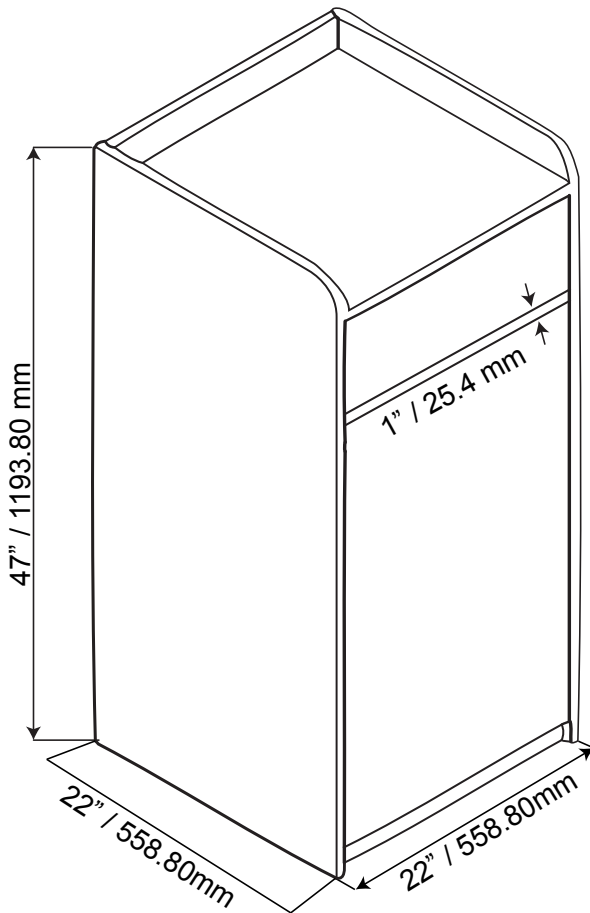

## OMCAN INC.

Telephone: 1-800-465-0234  
 Fax: (905) 607-0234  
 Email: sales@omcan.com  
 Website: www.omcan.com



Follow us to keep up to date with the latest news and offers

