

Merchandising Freezer 0.4

Technical Data Sheet

The Migali Merchandising Freezer is the world's first commercial merchandising freezer to use Phononic's solid-state technology to create and maintain consistent cooling. Compact, modern and quiet, it allows you to move high-margin frozen products out of deep ice chests and onto checkout counters, bar tops, concession stands, or other spots where space or environmental constraints may have prohibited compressor-based freezer placement in the past. The Migali Merchandising Freezer fits perfectly in grocery and convenience stores, restaurants, bars, hotels and stadiums.

With a Migali freezer, you can say goodbye to noisy, bulky and energy-hogging compressors and fans and hello to:

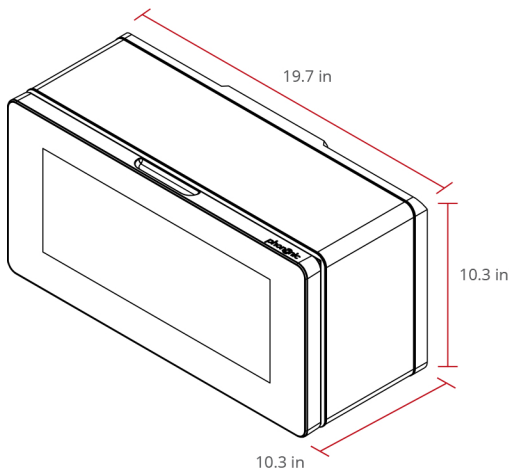

Features

- Solid-state freezer system delivering consistent performance at -18 °C
- Small form factor and low exhaust and vibration for optimal retail placement at the point of sale
- Easy-to-access angled slide door with balanced close mechanism
- Non-hazardous refrigerant
- Clear bin for inventory view
- Customizable look using personalized, interchangeable magnetic print images

Keep foods at the right temperature, in the right locations

Compressor-free cooling is setting new standards in capacity, reliability, efficiency, sustainability and security, so you can:



Sell more at the point of sale

Display the most profitable frozen products where they'll reach the most customers - not at perimeter walls, as is common today.



Deliver consistent cooling at lower cost

Fast recovery and optimal design keep food frozen, even with frequent openings. Realize increased temperature stability (less than half the variability of Energy Star freezer standards) and reduce total kWh.



Cut maintenance time and costs

Replace traditional freezers with long-lasting, reliable solid-state technology to spend less time and expense on maintenance.



Modernize countertop and consumer-facing displays

Aesthetic designs and near-silent operation looks great at point of sale and offers novel merchandising to meet consumer preferences.

Version 1001D

Model		Migali Merchandising Freezer 0.4
Basic Information	Materials	Painted Steel, Aluminum, Plastic, Tempered Glass
	Power Input	100-240VAC 50Hz-60Hz (external brick, 200x100x30mm)
	Power Cord	1.8 Meter, NEMA 5-15/CEE 7-7/BS, 1363 Grade Plug
	Internal Lighting	Yes
Performance	Temperature Set-point	-18 °C
	Temperature Uniformity	3 °C
	Temperature Stability*	< 1 °C
	Noise Level	39 dBA (steady-state); 50 dBA (max)
	Energy Requirements	2.9 kWh/day @ 24 °C Ambient
	Amps	Amps 0.95-2.6 amps max, >0.4-1.2 amp steady-state
Safety	Certifications	UL 471, FCC, REACH, RoHS, NSF-7
	Refrigerant	R744 (CO ₂)
Storage	Internal Volume	0.42 cubic feet
	Storage Bin	Clear Polycarbonate
	Packing Factor	Up to 24 ice cream sandwiches
	Internal Dimensions	16.9"W x 6.2"D x 7.0"H; 429mm W x 157mm D x 179mm H
Installation	External Dimensions	19.7"W x 10.3"D x 10.7"H; 500mm W x 271 mm D x 262mm H
	Shipping Weight	42 lbs
	Minimum Clearance Requirement	50mm top/back
Warranty	Heat Pump	10 years
	Full Refrigerator Parts and Labor	1 year

* Ambient range 10-32 °C, 40-70% RH, Elevation up to 2000M, Pollution Degree 2, IP3x

Version 1001E