

ITEM #: \_\_\_\_\_ QTY: \_\_\_\_\_  
 MODEL #: \_\_\_\_\_  
 PROJECT NAME: \_\_\_\_\_

051018

3601 S. Banker St. Effingham, IL 62401 • P.O. BOX 609 • Ph: (888) 431-2667 • Fax: (800) 433-2667

## **"PPB" PRO PREP BLOCK**

### **4" THICK BLOCK**

#### **FEATURES:**

- NORTHERN HARD ROCK MAPLE 4" THICK END GRAIN TOP
- STANDARD WITH BOOS BLOCK CREAM FINISH W/ BEESWAX
- STANDARD WITH 1-1/4" ROUND STAINLESS STEEL TIE BARS
- OPTIONS: UTENSIL DRAWER: D14 - 15" 4 - 2-1/2", DRAWER NOT AVAILABLE ON PPB242  
 COMMERCIAL GRADE LOCKING CASTERS: CAS03  
 POT RACK: POTR



PPB2424

### **PRO PREP BLOCK**

MODEL #	QTY
PPB2424	
PPB3024	
PPB3030	
PPB3624	

## DETAILED SPECIFICATIONS

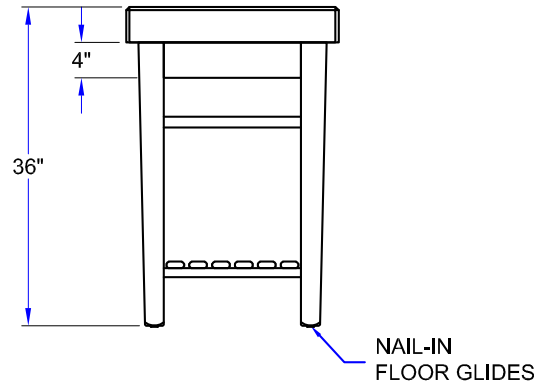
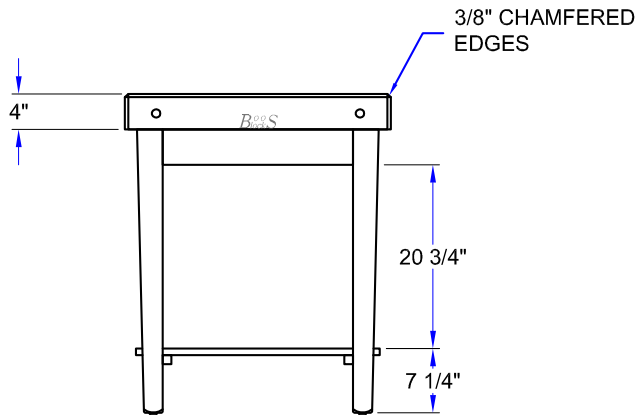
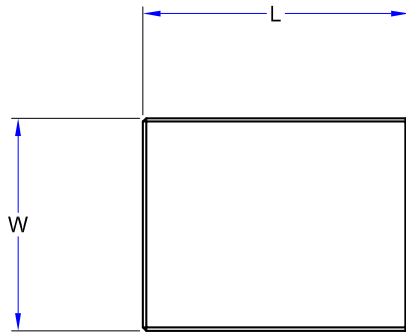

### PRO PREP BLOCK

MODEL #	SIZE	HEIGHT	WEIGHT (LBS)
PPB2424	24" X 24" X 4"	36"	105
PPB3024	30" X 24" X 4"	36"	115
PPB3030	30" X 30" X 4"	36"	125
PPB3624	36" X 24" X 4"	36"	160

SOME UNITS SHIP UNASSEMBLED FOR REDUCED SHIPPING COST. ALL DIMENSIONS ARE TYPICAL. TOLERANCE +/- .500"  
 John Boos & Co. is constantly engaged in a program of improving products and therefore reserves the right to change specifications without prior notice.



3601 S. Banker St. • Effingham, IL 62401 • PO BOX 609 • [quotes@johnboos.com](mailto:quotes@johnboos.com)

[www.johnboos.com](http://www.johnboos.com)