



**GAS**

PRO SERIES | GAS CONVECTION OVENS

**IMPERIAL**



## GAS CONVECTION OVEN FEATURES

- One hand opens and closes both doors simultaneously
- 60/40 doors swing open to 130°
- Large window
- Two interior lights
- Digital electronic controls
- Stainless steel exterior
- Rugged ½ HP 2 speed motor per oven
- Porcelainized oven interior for easy cleaning and better browning
- Five oven racks with 10 rack positions
- Most spacious oven interior available
- Curved corners for easy cleaning.

### Model Numbers

ICVG-2  
ICVDG-2

## ICVG-2

Shown with optional casters.



- Updated door handles

### PROGRAMMABLE CONTROLS WITH COOK 'N HOLD FEATURE

- Easy-to-program. Simply select the time, temperature, fan settings and hold mode - then preset buttons.
- Cook 'n Hold feature. Cooks at a higher temperature for browning. Automatically switches to a lower holding temperature.
- 24 hr. digital countdown timer with easy-to-read LED digital display.
- Cooking versatility.  
Fan option lets you choose modes:  
1. Fan on continuously  
2. Fan on when heat is on pulsed fan feature.
- °F or °C readings can be displayed.

### MANUAL CONTROLS

- Independent time and temperature controls give you maximum versatility for general baking and roasting.
- 2-speed fan switch controls bake or roast.

### THERMOSTATIC OVEN CONTROL

- Snap action temperature control 150° F to 500° F. (66° C to 260° C).

### ON-OFF SWITCH

- 60 minute manual timer.
- Audible buzzer lets you know when the cooking cycle is complete.



Notes: Measurements in ( ) are metric equivalents.



**GAS**

PRO SERIES | GAS CONVECTION OVENS

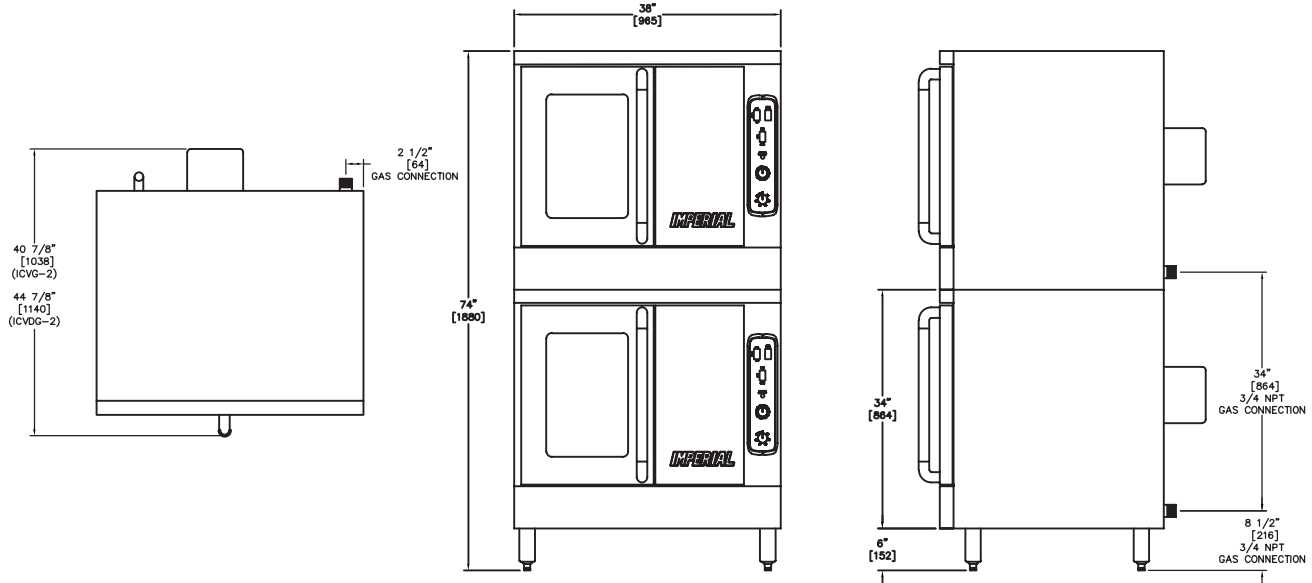

**GAS CONVECTION OVENS**

MODEL	DESCRIPTION	GAS OUTPUT BTU	GAS OUTPUT KW	SHIP WEIGHT KG	SHIP WEIGHT LBS
ICVG-2	DOUBLE DECK, STANDARD DEPTH	140,000	41	455	1,005
ICVDG-2	DOUBLE DECK, BAKERY DEPTH	160,000	47	536	1,185

MODEL	DIMENSIONS	CRATED DIMENSIONS
ICVG-2	38" W X 41-1/2" D X 74" H (965 X 1054 X 1880 MM)	40" X 47-1/2" X 72" (1016 X 1206 X 1829 MM)
ICVDG-2	38" W X 45-1/2" D X 74" H (965 X 1156 X 1880 MM)	40" X 51-1/2" X 72" (1016 X 1308 X 1829 MM)

MANIFOLD PRESSURE		
NATURAL GAS	PROPANE GAS	MANIFOLD SIZE
5.0" W.C.	10.0" W.C.	3/4" (19 MM)

**UTILITY REQUIREMENTS GAS MODELS**

VOLTAGE	PHASE	HZ	AMPS MAX
120	1	60/50	9

**EXTERIOR**

- Stainless steel exterior, except back. Reflects a quality, professional look for exhibition cooking
- Welded and finished seams
- Stainless steel legs
- Easy to clean and maintain
- One year parts and labor warranty

**OPTIONS AND ACCESSORIES**

- Cook and Hold computer controls
- Stainless steel back enclosure
- Direct connect vent
- Heavy duty casters, set of 4
- Stack kit with 6" (152) stainless steel legs
- One point gas connection for double stack ovens
- Stainless steel solid doors

**CLEARANCE**

For use only on non-combustible floors with legs or casters; or 2 1/4" (57 mm) overhang is required when curb mounted. 0" clearance from non-combustible side and rear walls. Provide 6" (152 mm) minimum clearance from combustible side walls and 0" from combustible wall at rear.

