

# Ice/Beverage Series 820C Remote Ice Cube Machine

with Patented CVD Technology<sup>®</sup>

## Models

IBF-0820C



**An Ice Machine Designed Specifically for Beverage Dispensers**



Ice/Beverage Series 0820C ice machine - 115V  
Servend SV-250 beverage dispenser  
An "NSF Listed" Ice/Beverage Dispenser Combination

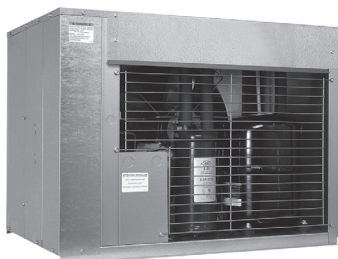

CVD Condensing Unit - 208-230V

QuietQube ice machine with CVD condensing unit is designed as a Manitowoc system and cannot be used with any other ice machine or remote condenser brand.

## Standard Features

IB Series QuietQube<sup>®</sup> Remote System consists of a remote condensing unit, interconnecting refrigerant lines, ice machine head section along with a countertop dispenser, or ice storage bin. All ordered separately.

- **Space-Saving Design** - up to 825 lbs ( 374 kg ) daily ice production in narrow 22" footprint eases sanitation procedures for the ice storage area and beverage valves.
- Also allows for convenient manual loading of ice in dispenser to satisfy peak ice usage.
- Can be installed or retrofitted to virtually any commercial beverage dispenser.
- Only 14" (35.56 cm) deep, 22" (55.88 cm) wide, and 26.5" (67.30 cm) high.
- **Quiet Operation** - eliminates most noise from the refrigeration system. Promotes a relaxing atmosphere.
- **Intelligent Diagnostics** - provide 24 hour preventative maintenance and diagnostic feedback for trouble free operation.
- **Acoustical Ice Sensing Probe** - Unique patented technology allows for reliable operation in challenging water conditions and environments.
- **easyTouch<sup>®</sup> display** - New icon based display, takes the guess work out of owning and operating an ice machine
- **Programmable Ice Production** - Now its super easy to program your ice machine to be off at certain times of the day to save money with fluctuating electrical rates. Also programmable by daily ice production volume and night time programming.
- **Easy to Clean Foodzone** - Lift-off front door for easy access. Removable water-trough, distribution tube, curtain, and sensing probes for fast and efficient cleaning. Select components made with AlphaSan<sup>®</sup> antimicrobial.
- **DuraTech<sup>™</sup> Exterior** - provides superior corrosion resistance. Stainless finish with innovative clear-coat resists fingerprints and dirt.
- **Available LuminIce II Virus and Bacteria Inhibitor**- Controls viruses, bacteria, mold and yeast within the food zone to keep the machine clean longer. a new sanitation icon lets you know the operational status.
- **Active Sense** - Insures consistent ice harvest in all environmental conditions. This software solution works in conjunction with the acoustical ice sensing probe improving reliability and performance

## Ice Shape



**Half Dice**  
3/8" x 1 1/8" x 7/8"  
(.95 x 2.86 x 2.22 cm)



Ice/Beverage Series 820C Remote Ice Cube Machine





### Ice/Beverage IBF0820C Ice Machine

**Installation Note**  
Minimum installation clearance:  
Top: 2" (5 cm)  
Back: 5" (13 cm)  
Sides: 8" (20.3 cm)  
(additional space for servicing may be required)

Shipping Weight:  
137 lbs. / 62 kg

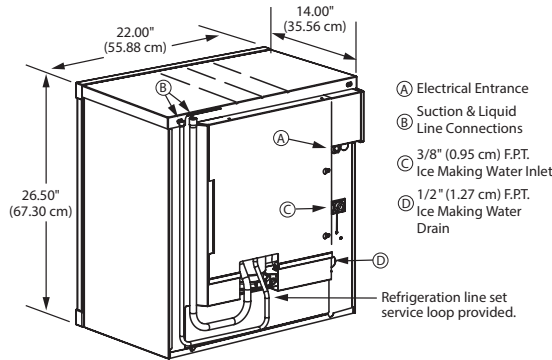

### CVDF0900-A Condensing Unit

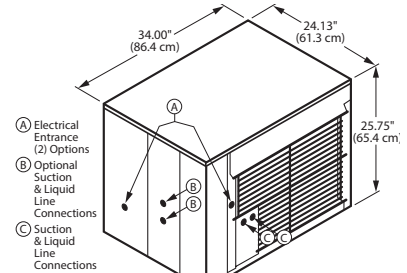

Shipping Weight:  
208 lbs. / 94 kg

### Ice Machine Electric

**115/60/1 standard.**  
**Total Amps:** 1.1  
**Max. fuse size:** 15 amps  
HACR-type circuit breakers can be used in place of fuses.

### Specifications

**Operating Limits:**  
Ambient Temperature Range: 40° to 110° F (4.4° to 43.4° C)  
Water Temperature Range: 40° to 90° F (4.4° to 32.2° C)  
Water Pressure Ice Maker Water In: Min. 20 psi (137.9 kPa) Max. 80 psi (551.1 kPa)  
**Refrigerant:** R-404A

**208-230/60/1standard.** 208-230/60/3 HACR-type circuit breakers can be used in place of fuses.  
**Note:** QuietQube ice machine power supply is wired independent of CVD condensing unit.

**Min. circuit ampacity:**  
11.5 1ph                      7.1 3ph  
**Max. fuse size:**  
20 amps 1ph                      15 amps 3ph

HACR-type circuit breakers can be used in place of fuses.

**BTU Per Hour:**  
12,700 (average) 14,800 (peak)

**Compressor:**  
Nominal rating: 1.5 HP

**Operating Limits:**  
Ambient Temperature Range:  
-20° to 120° F (-29° to 48.9° C)

#### Installation Information and Dimensions:

Maximum Line Length  
—100' (30.5 m).\*

Maximum Vertical Rise\*  
—35' (10.7 m) above ice machine.

Maximum Vertical Drop  
—15' (4.5 m) below ice machine.

\*A rise over 20' (6 m) requires S-Trap Kit K-00172 - ordered separately.

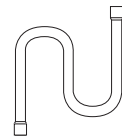

### Remote Air-cooled Ice Machine

Model	Ice Shape	Ice Production 24 Hours		Power kWh/ 100 lbs. @90°Air/70°F*	Potable Water Usage/ 100 lbs. Ice*	ENERGY STAR®
		70°Air/ 50°F Water	90°Air/ 70°F Water			
IBF0820C	half-dice	825 lbs.	728 lbs.	5.0	19.6 gal.	★
		374 kg	330 kg			

Ice machine for use with ice dispenser, CVD condensing unit and dispenser adapter. All ordered separately. kWh per 100 lbs. is total power of ice machine and condensing unit. Ice machine is 1 ph only. Condensing unit is 1 ph or 3 ph.



\*Ratings Certified in Accordance with AHRI Standard 810.

### Indigo NXT Remote Tubing Kits

Model	Line Length		Weight	
	ft.	m	lbs.	kg
RC-21	20	6	12	5
RC-31	30	9	17	9
RC-51	50	15	27	13



**Note:** IB models are designed for use with an Ice/Beverage dispenser.

Adapter required. Ordered separately. For attachment to ice storage bin, contact factory.

### Accessories

#### LuminIce® II Virus and Bacteria Inhibitor

controls viruses and bacteria inside the ice machine



#### External Scoop holder

protect the ice scoop with the NSF approved versatile scoop holder.



#### Arctic Pure® Water Filters

reduces sediment and chlorine odors for better tasting ice.



**iAuCs®** schedules and performs routine ice machine cleaning automatically.



Welbilt reserves the right to make changes to the design or specifications without prior notice.