



Project _____

Item # _____

Quantity _____

Macho Nacho[®] Chip Warmers

Models: FDWD-1-MN,
FST-1-MN

The Hatco Macho Nacho[®] Holding and Display Cabinet is a high-visibility merchandiser for warming and displaying nacho chips. These heated displays use no humidity, and keep chips hot, fresh and crisp considerably longer than other warmers, reducing refill time and minimizing waste. The FDWD-1-MN holds up to 25 lbs. (11 kg) and the FST-1-MN holds up to 40 lbs. (18 kg)

The unique air flow forces warm air to the bottom and is distributed into the cabinet through holes in the floor panels, directing maximum heat to the chips being served. Macho Nacho[®] circulates air to prevent the loss of natural oils, eliminating the need to frequently replace stale chips.

Standard features

- Two-door access permits easy loading and serving. Chips flow to the front of the cabinet when loading through the upper door and the heated, slanted floor panel slides the hot chips to the lower door for serving
- Built of stainless steel and aluminum with tempered glass sides and doors with chip slide and floor panels that are removable for ease of cleaning
- Shatter-resistant incandescent lights enhance food appeal while safeguarding food products from bulb breakage
- Snappy graphic decals for three sides help promote product
- Anodized bronze finish is standard on the FST model



FST-1-MN with
standard bronze finish

FDWD-1-MN

Options (available at time of purchase only)

Color for FST model only

- Non-standard colors are non-returnable – Bronze Finish standard
- Clear Anodized Finish



For operation, location and safety information, please refer to the Installation and Operating Manual.



HATCO CORPORATION | P.O. Box 340500 Milwaukee, WI 53234-0500 U.S.A. | (800) 558-0607 | (414) 671-6350



www.hatcocorp.com | support@hatcocorp.com | [Find a Hatco Rep](#) | [Image Library](#) | [Document Library](#) | [Chat](#)



Macho Nacho[®] Chip Warmers

Models: FDWD-1-MN, FST-1-MN

FDWD-1-MN

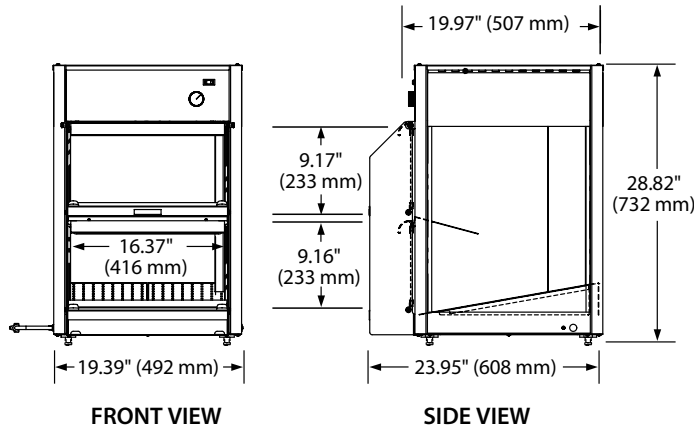

FST-1-MN

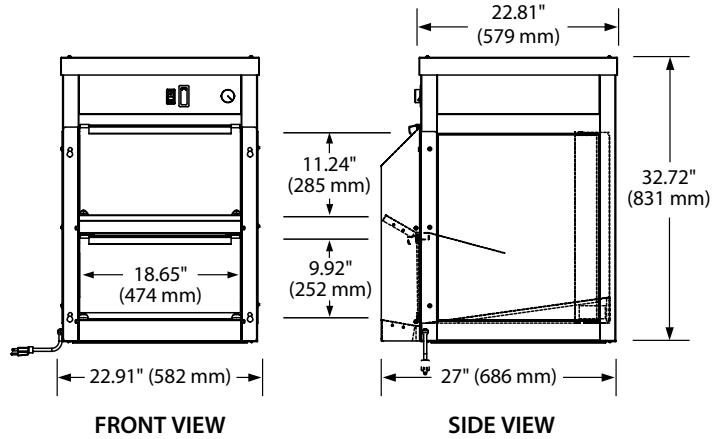

SPECIFICATIONS Chip Warmers - Non-Humidified

The shaded areas contain electrical information for International models

Model	Description	Dimensions (W x D x H)	Cabinet Opening (W x H)	Volts	Watts	Amps	Plug	Ship Weight*
FDWD-1-MN	2 Doors	19.39" x 23.95" x 28.82" (492 x 608 x 732 mm)	Upper Door: 16.37" x 9.17" (416 x 233 mm) Lower Door: 16.37" x 9.16" (416 x 233 mm)	120	1080	9.0	NEMA 5-15P	101 lbs. (46 kg)
				220	950	4.3	CEE 7/7 Schuko	
				240	1129	4.7	BS-1363	
FST-1-MN	2 Doors	22.91" x 27" x 32.72" (582 x 686 x 831 mm)	Upper Door: 18.65" x 11.24" (474 x 285 mm) Lower Door: 18.65" x 9.92" (474 x 252 mm)	120	1245	10.4	NEMA 5-15P	132 lbs. (60 kg)
				220	1219	5.6	CEE 7/7 Schuko, AS 3112	
				240	1252	5.2	AS 3112, BS-1363	

* Shipping weight includes packaging.

CORD LOCATION

Facing controls, left-hand side panel, bottom right corner.

PLUG CONFIGURATIONS

NEMA 5-15P

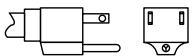

CEE 7/7 Schuko

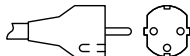

AS 3112

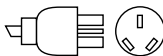

BS-1363

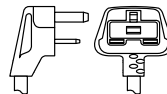

PRODUCT SPECS Chip Warmers

The Holding and Display Cabinet shall be a Flav-R-Fresh[®] (or Flav-R-Savor[®]) Macho Nacho[®] Model ... as manufactured by the Hatco Corporation, Milwaukee, WI 53234 U.S.A.

The Chip Warmer Cabinet shall be rated at ... volts and ... watts and be ... inches (millimeters) in overall width.

It shall consist of two doors, tempered glass sides and doors, incandescent display lights, and merchandising graphics. A 6' (1829 mm) cord with plug shall be attached. Warranty consists of 24/7 parts and service assistance (US and Canada only).

HATCO CORPORATION | P.O. Box 340500 Milwaukee, WI 53234-0500 U.S.A. | (800) 558-0607 | (414) 671-6350



www.hatcocorp.com | support@hatcocorp.com | [Find a Hatco Rep](#) | [Image Library](#) | [Document Library](#) | [Chat](#)