



TILTING BRAISING PAN

GAS MODELS BPM-30/40GC/GA/GC2T

Braising pan shall be a Groen gas heated manual tilting BPM Series (specify 30 or 40 gallon, Classic (C), Advanced (A) or Cook2Temp™ (C2T™) controls) model with 10" deep pan body with 3" radius corners, 5/8" thick stainless steel clad cooking surface mounted on open leg stand with height-adjustable bullet feet. CookTemp models also come with a probe.

AVAILABLE MODELS:

CLASSIC CONTROLS:

- BPM-30GC (30 GALLON)
- BPM-40GC (40 GALLON)

ADVANCED CONTROLS:

- BPM-30GA (30 GALLON)
- BPM-40GA (40 GALLON)

COOK2TEMP CONTROLS:

- BPM-30GC2T (30 GALLON)
- BPM-40GC2T (40 GALLON)

CONSTRUCTION: The pan body shall be of type 304 stainless steel, solid one-piece welded heavy-duty construction, with 10" pan depth. All exposed surfaces shall be stainless steel. The cooking surface is a heavy 5/8" thick stainless steel clad plate with specially designed welded heat transfer fins, heated by the gas burner/combustion chamber. This combination delivers more uniform heat transfer over the entire cooking surface. The heavy plate prevents warping or distortion. Controls and tilt mechanism are mounted in a stainless steel water resistant IPX6 rated housing at the right side of the pan body. Braising pan shall come standard with a mounting bracket for either right-side, left-side or right-rear faucet mounting. Graduated fill-level marks in both gallons and liters are standard.

FINISH: Interior of braising pan shall be polished to a 100 emery grit finish on C/A models, 180 emery grit on C2T models. Exterior of braising pan shall have a #3 finish, ensuring maximum ease in cleaning and maintaining appearance.

CSA DESIGN CERTIFICATION: Braising pan shall be design-certified by CSA International (formerly AGA) for use with Natural Gas or LP Gas.

SANITATION & NSF LISTING: Braising pan shall be designed and constructed to be NSF listed, meeting all known health department and sanitation codes. True open leg tubular design and 3" radius pan interior make cleaning easier.

MANUAL TILT: The braising pan shall have a smooth-action, quick-tilting body with manual crank and worm-and-gear tilt mechanism, which provides precise control during pouring. Pan body shall tilt to vertical in 24 turns and past vertical to assist in cleaning.

CONTROLS: All controls to be located in a right-front mounted water resistant (IPX6 rated) enclosure:

Classic -C Models include: Power ON-OFF switch with indicator light, temperature control knob with 175 to 400°F (79 to 204°C) range increments and HEAT(ing) indicator light;

Advanced -A Models include: Same control features as Classic models with the addition of temperature and time set knob (175 to 400°F/79 to 204°C range), LED display of set temperature or cook time, buttons for reset of Low Temp and High Temp presets, MANUAL mode button for knob-setting of pan temperature, and TIMER-set button with indicator light;

Cook2Temp -C2T Models include: Same control features as Classic and Advanced models with the addition of Auto C2T and Manual C2T buttons with core probe connection port, MANUAL mode button for knob-setting of pan temperature for manual cooking and manual C2T cooking.

PERFORMANCE FEATURES: Braising pan shall be equipped with controls that allow operation at 7 degree angle to facilitate griddling. Braising pan shall be thermostatically-controlled for automatic shut-off when desired temperature is reached and automatic power ON when temperature falls below desired setting. BPM-30GC and 30GA Models have a firing rate of 104,000 BTU/hr. BPM-40GC and -40GA Models have a firing rate of 144,000 BTU/hr. Electronic intermittent pilot ignition system is standard. Braising pans have high limit thermostat as a safety feature.

INSTALLATION: Unit requires 1/2" NPT gas connection. Requires 115 Volt, single-phase, 60 HZ, 5 AMP electric supply.

ORIGIN OF MANUFACTURE: Designed and manufactured in the United States.

PROJECT NAME:	
LOCATION:	
ITEM NO:	
QTY:	
MODEL NO:	
AIA NO:	
SIS NO:	
CSI SECTION:	



BPM-30GA Model shown

OPTIONS/ACCESSORIES:

- Single pantry water fill faucet
- Double pantry water fill faucet
- Single or double pantry faucet with spray hose assembly (48" or 60")
- Steamer pan carrier
- 2" tangent drawoff valve (option: must be ordered with unit)
- Strainer for tangent draw-off valve
- Gas quick disconnect
- Caster kit w/restraint cable
- Flanged feet
- Pouring lip strainer
- Steamer pan inserts
- Replacement core probe (on C2T models only)



P/N 146195 REV G

TABLE OF DIMENSIONS			
MODEL	BPM-30G	BPM-40G	
DIMS.	INCH	MM	INCH
A	26.25	667	35.75
B	32.00	813	41.50
C	38.50	984	48.00
D	8.75	222	13.50
E	8.90	225	13.60
F	17.10	435	21.90

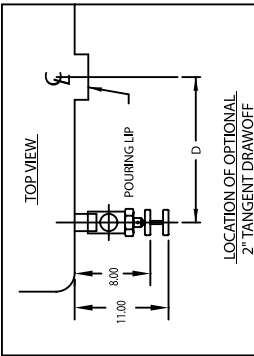

PERFORMANCE DATA		
MODEL	BPM-30G	BPM-40G
FIRING RATE BTU/HR	104,000	144,000
CAPACITY GALLONS	30	40
	LITERS	114

GAS FEED RATE: INCHES WATER COLUMN -RECOMMENDED INCOMING-	
NATURAL GAS	4.5" W.C. MIN. 14" W.C. MAX.
PROPANE GAS	11" W.C. MIN. 14" W.C. MAX.

NOTES:

1. DIMENSIONS IN BRACKETS [] ARE MM.
2. CASTERS OR FLANGED FEET AVAILABLE AT AN EXTRA COST.
3. ELECTRICAL CONNECTION: 0.875" DIA. (22) HOLE 115 V, 1 PH, 60 HZ, 5 AMPS.
4. GAS CONNECTION: 1/2" NPT.
5. ELECTRIC POWER NOT REQUIRED ON OPTIONAL STANDING PILOT MODELS (BPM-30GS & 40GS).
6. FAUCET BRACKET MAY BE INSTALLED ON LEFT OR RIGHT SIDE.
7. THE SIZE AND LOCATION OF DRAIN TROUGH ARE FOR REFERENCE ONLY. USER SHOULD CONSULT WITH LOCAL PLUMBING CODES FOR PLACEMENT OF UNIT OVER TROUGH. PRODUCT TO BE POLISHED AND RELATED VARIABLES.
8. TETHER REQUIRED WITH CASTERS TO SECURE UNIT.

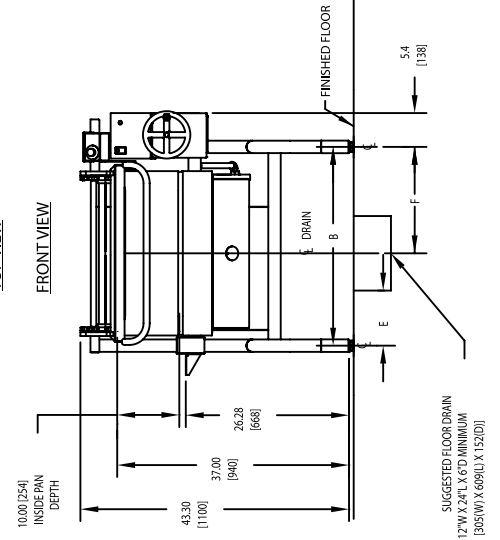
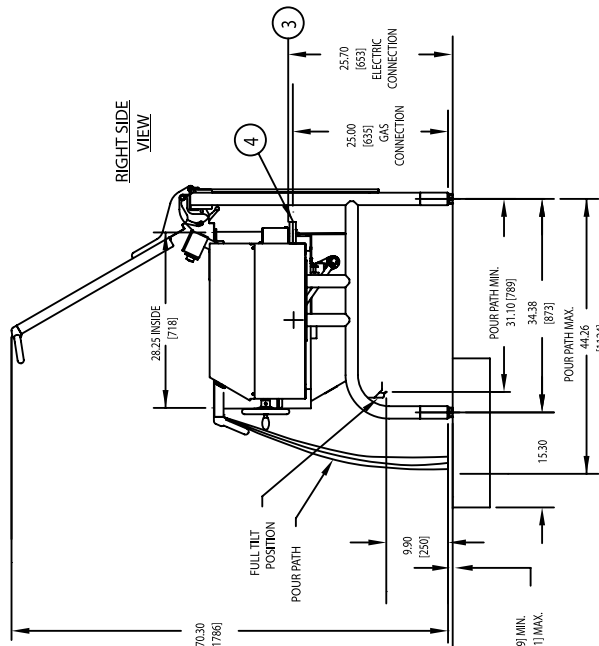
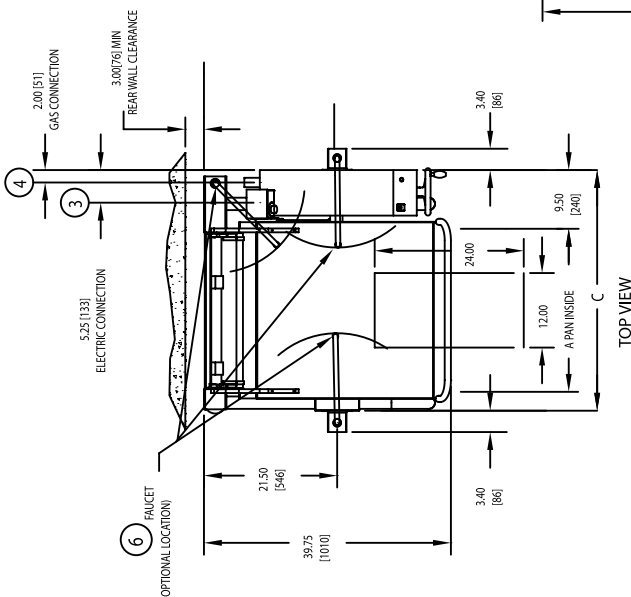

CLASSIC CONTROL



ADVANCED CONTROL



COOK2TEMP CONTROL