

Project: _____	AIA# _____
Item #: _____ Qty: _____	SIS# _____
Model #: _____	

One, Two And Three Door Dry Storage Cabinets

DS24, DS48, DS72



DS24
with black vinyl-clad door
and stainless steel top



Intertek
4004503
Conforms to NSF/ANSI STD 2

DS Configurable Options

Door Style & Finish:

- Door - Black vinyl-clad
- Door - Unlaminated
- Door - Stainless steel
- Door - Jeweled stainless
- Door - Laminated

Door Hinge Location (specify for each door):

- Left or Right

Door Handle:

- Polished stainless
- Polished brass
- Stainless pull tab

Top Style:

- No finished top
- Stainless top
- Laminated top

Left and Right Side Finish:

- Black vinyl-clad
- Stainless steel
- Laminated

Standard Features

- Galvanized steel interior construction
- Foamed-in-place insulated sides and door for extra sturdiness and sound deadening
- Galvanized steel sub-top on DS48 and DS72 models
- Black vinyl-clad steel exterior front and sides
- Stainless steel die cast handle with lock
- Leg sockets recessed into base
- 180° swinging doors

To view underbar installation instructions, please visit: http://www.glastender.com/PDF/F-750-165_Underbar_Installation_Instructions.pdf
 To view cleaning and care instructions, please visit: http://www.glastender.com/PDF/F-423-011_ss_clean_care.pdf

Specifications

Shelving

- Two adjustable shelves per door included

Legs

- 1-5/8" diameter
- Stainless steel bullet feet

Materials

- 22 gauge galvanized steel parts include: interior walls and back on all models, and sub-top on DS48 and DS72
- 22 gauge black vinyl-clad parts include: sides and standard doors
- 18 gauge stainless steel parts include: top front channel and front leg channel on DS24
- 16 gauge stainless steel parts include: legs
- 16 gauge galvanized steel parts include: shelf and base on DS48 and DS72, rear leg channel, floor, and shelves on DS24
- 16 gauge zinc plated CR steel parts include: leg sockets
- 12 gauge stainless steel parts include: hinges, hinge brackets, and lock brackets

Glastender, Inc. • 5400 N Michigan Rd • Saginaw, MI • 48604-9780
 989.752.4275 • 800.748.0423 • Fax 989.752.4444
www.glastender.com

Approval/Notes:

Specifications subject to change without notice. For current specifications please visit our website.

Dry Storage Cabinets

Dimensional Information

PLAN VIEW

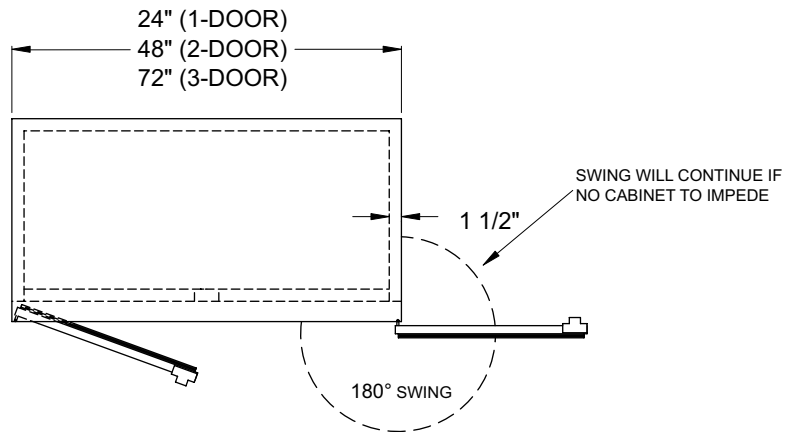

FRONT VIEW

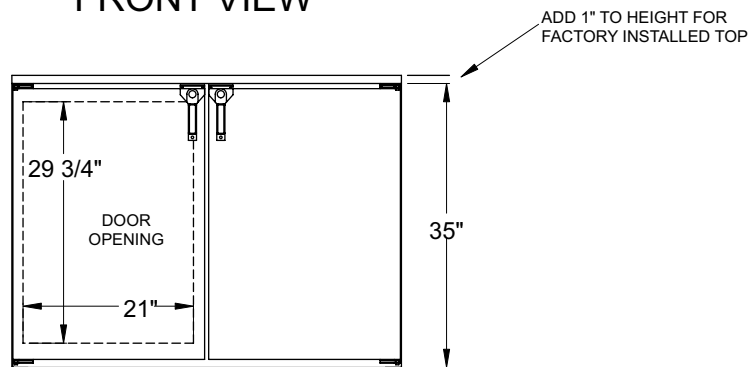

SIDE VIEWS

