

GAS STATIONARY FULL JACKET STEAM KETTLE

 GL-60FE

OPERATION SHALL BE BY:

- Natural Gas
- L.P. Gas

For operation on 115 VAC, 1 phase, 50/60 Hz

STANDARD FEATURES:

- Low water level cut-off and indicator
- Pressure gauge
- Temperature control.
- Safety relief valve, 35 PSI (241kPa) max design pressure
- Integrally mounted controls
- 2" (50 mm) draw-off valve
- Spring assist stainless steel cover
- Electronic ignition
- Water sight glass
- 100% safety gas shut-off control
- 316 stainless steel liner



OPTIONS & ACCESSORIES AT ADDITIONAL COST

- | | | |
|---|---|--|
| <input type="checkbox"/> 220 VAC, 1 phase, 50/60 Hz (GKVS-1) | <input type="checkbox"/> Draw-off valve hose kit (DVHK-) | <input type="checkbox"/> Single pantry faucet with swing spout (SF-12) |
| <input type="checkbox"/> 3" (76 mm) draw-off valve with perforated strainer (TVS-3) | <input type="checkbox"/> Tri-basket assembly (TBA-) | <input type="checkbox"/> Double pantry faucet with swing spout (DF-12) |
| <input type="checkbox"/> Etched gallon markings (GM-) | <input type="checkbox"/> Contoured measuring strip (CMS-) | <input type="checkbox"/> Single pantry faucet kettle filler (SP-KF-GK) |
| <input type="checkbox"/> Etched litre markings (LM-) | <input type="checkbox"/> Strainer hook (SH) | <input type="checkbox"/> Double pantry faucet kettle filler (DP-KF-GK) |
| <input type="checkbox"/> Correctional package | <input type="checkbox"/> Solid disc for draw-off valve (TSS-) | <input type="checkbox"/> Draw-off valve drain cup with hose (DVDC-) |

STANDARD CONSTRUCTION SPECIFICATIONS

Shall be a CROWN model GL-60FE, gas fired self-contained full jacket steam kettle, AGA, CGA and NSF Certified, ASME code stamped and National Board registered.

The kettle shall be constructed with an exterior of type 304 stainless steel, #4 sanitary finish and 6" (152 mm) stainless steel legs fitted with flanged adjustable feet.

The burners shall be of stainless steel high efficiency atmospheric tubular design and easily serviceable.

The interior kettle liner shall be a one piece all welded construction of type 316 stainless steel with # 4 sanitary finish, and shall be furnished with a 2" (50 mm) draw-off valve and a

spring assist stainless steel cover as standard.

The recessed control panel shall be located on the front side of the unit in full view of the operator and easy to use.

Standard controls shall include electronic ignition, direct immersion thermostat, water sight glass, cooking pilot light, vacuum/pressure gauge and low water indicator light.

Safety features shall include a low water cut off, pressure relief valve, pressure control and 100% safety gas shut-off valve.

The kettle shall operate in a temperature range of 165°F to 265°F (74°C to 130°C).



Approval Notes: _____

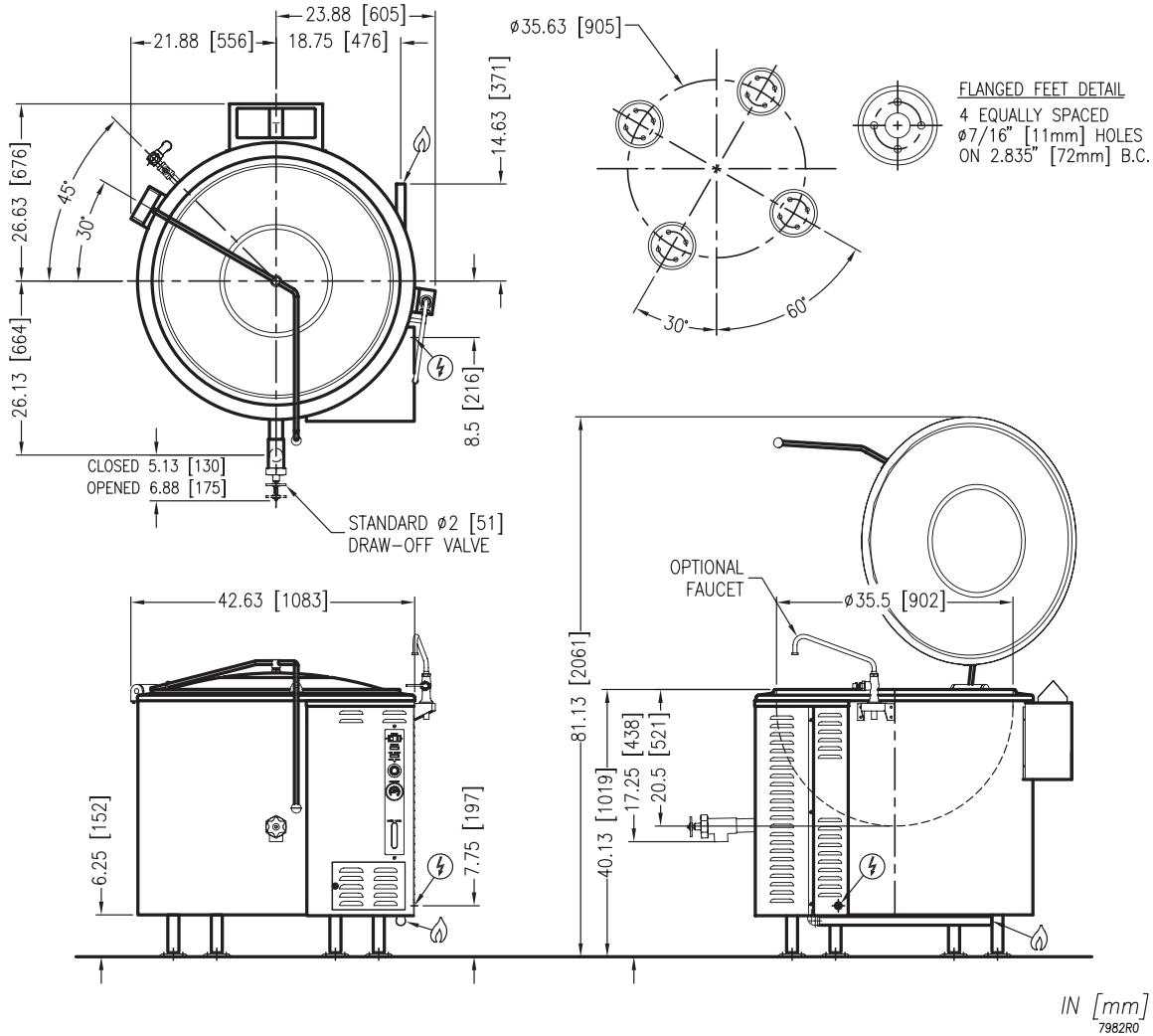

SERVICE CONNECTIONS

- Supply gas through 3/4" pipe. A gas shut-off valve must be installed in supply piping convenient and adjacent to appliance
- Unless other wise specified, Field Wire Electrical Connection to be 120 Volts, 60 Hertz, single phase with grounding wire. Unit furnished with 6' cord and 3 prong plug. Total maximum amps 2.0.

GAS CHARACTERISTICS

MODEL	GAS SUPPLY		
	BTU/HR.	kw/HR.	SUPPLY PIPE PRESSURE (W.C.)
GL-60FE	150,000	44.0	Natural 6"-14" (152-356 mm) Propane 11"-14" (279-356 mm)

* For use on non-combustible floors only.

SPECIFICATIONS

MODEL	CAPACITY	
GL-60FE	60 Gallon	227 Liter

MODEL	SHIPPING WEIGHT	MINIMUM CLEARANCE	
GL-60FE	800 lbs. [318 kg]	SIDES BACK	6" [152 mm] 2" [51 mm]

**INTENDED FOR COMMERCIAL USE ONLY.
 NOT FOR HOUSEHOLD USE.**

