

Model No.

**GFR36**



**GFR36**

## Features:

- HC refrigerant
- Forced-air cooling
- INTERIOR: Stainless Steel
- EXTERIOR: Steel painted black
- Chills glass and plate at -10° F
- Electronic thermostat & digital LED temperature display for accurate control & easy reading
- Two shelves and bottom rack standard
- Built-in condensate evaporator system
- No floor drain or additional plumbing is needed

Serv-Ware GFR Series Frosters are UL Safety and UL Sanitation Approved.

Featured with black painted steel exterior, and stainless steel interior, lockable sliding top, digital controls with a LED readout and foamed in place polyurethane cell insulation. LED internal lamp for high visibility of merchandise displayed for easy access. Unit is shipped with wheels installed.

The bottom mounted compressor designed to hold temperatures between -4° F and 5° F.

## Warranty Info:

### Two Year

- Parts & Labor on entire unit.
- Valid in United States.
- Valid for commercial use only.

### Three Year

- Additional Compressor, Part Only.



\* See last page for more information.



Conforms to UL471, CSA C22.2 and NSF 7 Standards.

Revised 03/25/2020

**GFR36**

Phone:(800).768.5953  
Fax:(800).976.1299

[www.servware.com](http://www.servware.com)  
Copyright © 2020 Serv-Ware Products Inc.

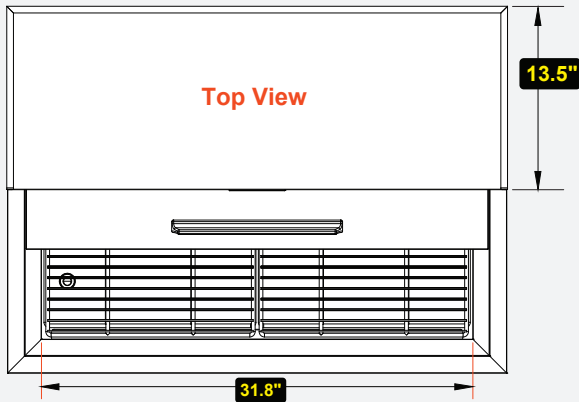
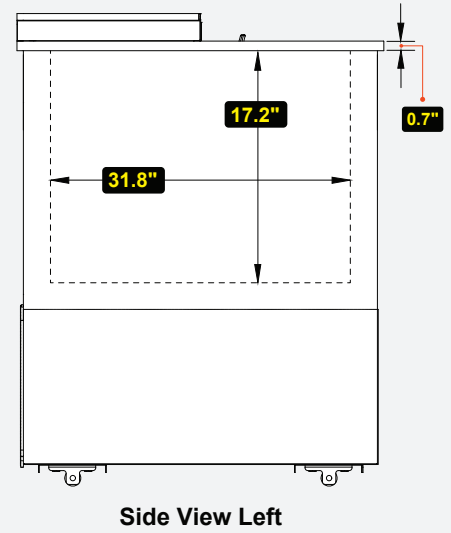
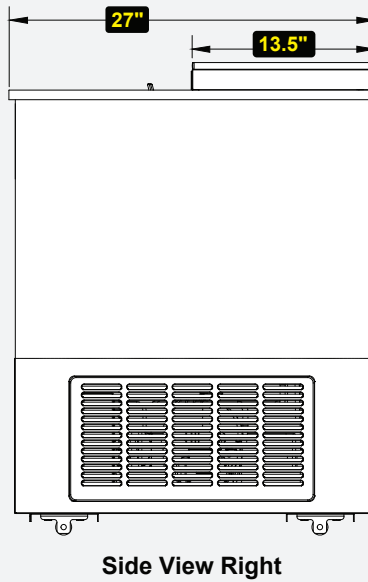
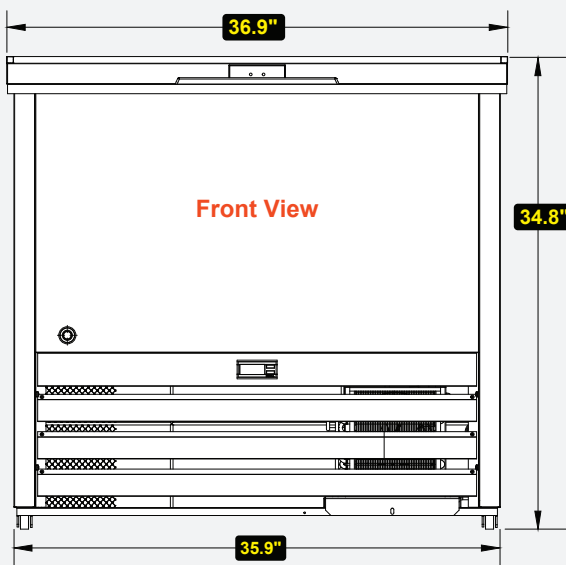

**NEMA 5-15P**

**Technical Information:**

MODEL #	DESCRIPTION	DIMENSIONS	WEIGHT/LBS.
		( W x D x H )	(Shipping)
GFR36	36 in. Unit	36.9" W x 27" D x 34.8" H	220 lbs.

CONSTRUCTION	
Exterior Material	Steel Painted Black
Interior Material	Stainless Steel
Insulation Material	CFC Free Foam
Shelf Material	2

COOLING	
Temperature Range	-4°F – 5°F
Refrigerant + Charge oz.	R290 / 3.53 oz.
BTU/H	866
Defrosting	Every 6 Hours
Horse Power	1/5
Storage Capacity	4.50 cubic feet

ELECTRICAL	
Voltage	115
Amps	2.0
Hz	60
Phase	1

**ADDITIONAL INFORMATION**

*Installation by certified commercial restaurant equipment installer recommended. Inspection before and after installation by licensed electrician for safe operation. Product designed for interior usage in a climate controlled location with adequate air circulation and not adjacent to a high temperature source.*



Prop. 65 Warning for California Residents  
 WARNING: This product may contain chemicals known to the State of California to cause cancer, birth defects, or other reproductive harm.



Phone:(800).768.5953  
 Fax:(800).976.1299