

VICTORY[®]

ULTRASPEC

PROJECT: _____

ITEM # _____ QTY: _____

MODEL # _____

AIA # _____ SIS # _____

PASS-THRU SOLID HALF-DOOR REACH-IN FREEZER

FS-2D-S1-PT-HD-HC



CABINET CONSTRUCTION

- Stainless Steel Exterior And Interior
- Stay-Open Door Feature For Easy Product Loading
- 20 Gauge Stainless Steel Solid Half-Door
- Magnetic Door Switch Automatically Activates Interior LED Light
- Heavy-Duty Cylinder Locks
- Stainless Steel Interior Door Liner
- One Piece, Snap-In Magnetic Door Gaskets
- Low Profile Vertical Door Handles
- Hinged Front Shroud
- Energy Saving Thermal Breaker
- Stainless Steel Breaker Caps
- 6 Silver Freeze Wire Shelves
- 6" High Adjustable Stainless Steel Legs
- 8' Cord And Plug (see electrical data for details)

FEATURES

- Full Electronic Control With Touchpoint Interface
- Expansion Valve Technology
- Manager's Lockout Feature
- Anti-Condensate Perimeter Heater
- Variable Speed Compressor Technology

REFRIGERATION

- Refrigeration System Uses R-290 Refrigerant To Comply With All Environmental Concerns
- Hot Gas Condensate Evaporator
- Adaptive Defrost For Reduced Energy Consumption And More Consistent Product Temperatures
- Epoxy Coated Evaporator Coil, Located Out Of The Food Zone
- Freezer Capable Of Maintaining Product Temperature -10°F



- ▶ 3 Year Parts & Labor Warranty Plus An Additional 4 Year Compressor Warranty
- ▶ Exclusive 2 Year Warranty On Magnetic Door Gaskets
- ▶ Lifetime Warranty On Handles & Hinges (parts only)



Please verify qualifying units by visiting:
www.energystar.gov/cfs

OPTIONS & ACCESSORIES

- Secure-Temp™ Technology
- Stainless Steel Case Back
- Stainless Steel Kick Plate
- Exterior Door Laminate
- Door Swing Orientation (at time of order)
- Additional Shelves
- Heat Shield (left, right)
- Tray Slides (type A & A/C)
- 3", 6" Casters Or 6" Seismic Legs
- FlexTemp Models Maintain Between 0°F And 20°F
- Correctional Package
- Remote Models* (6" legs only) (refrigerant must be specified at time of order, see note)

3779 Champion Blvd, Winston-Salem, NC 27105
 ph: (888) 845-9800 | fax: (800) 253-5168
 Sales@VictoryRefrigeration.com | VictoryRefrigeration.com

Rev. 9/30/21 Printed in U.S.A.

APPROVAL: _____ DATE: _____

PASS-THRU SOLID HALF-DOOR REACH-IN FREEZER

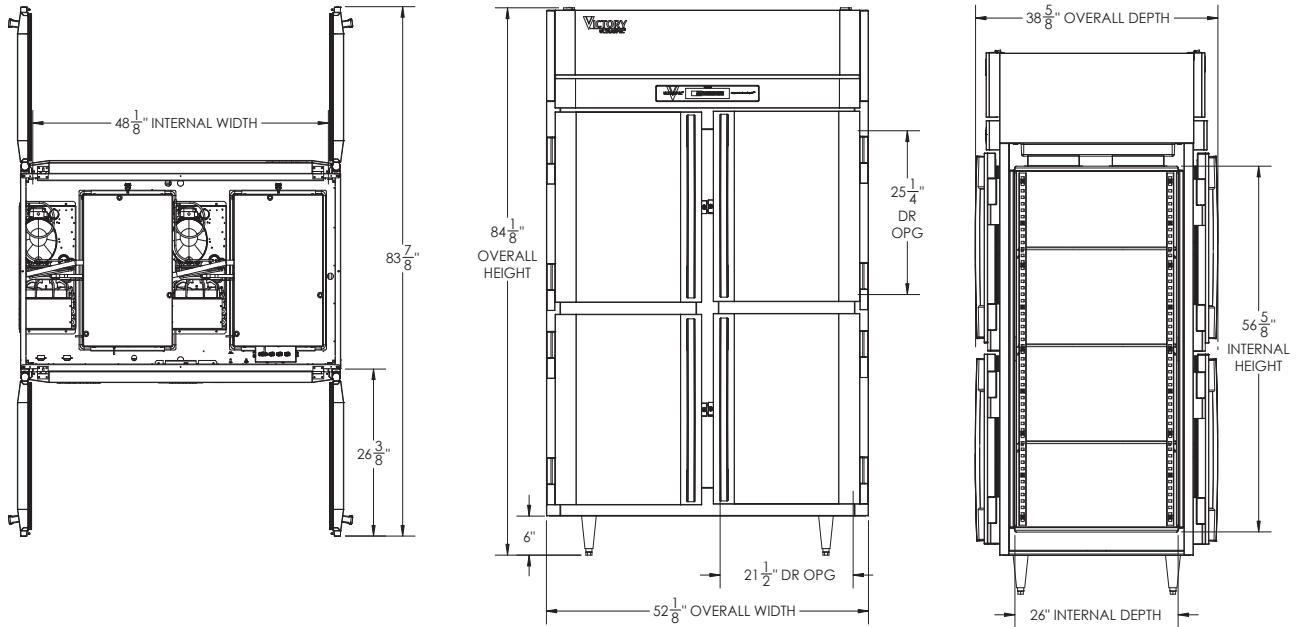

We reserve the right to change specifications and product design without notice. Such revisions do not entitle the buyer to corresponding changes, improvements, additions or replacements for previously purchased equipment. Dimensional tolerances +/- 1/4". Metric dimensions (MM)

12" Top and 3" rear clearance is required

CHARACTERISTICS		ELECTRICAL DATA		SHIPPING DETAILS	
Net Capacity (cubic ft.)	48.33	Cabinet Voltage	115/60/1	Height	88"
Width, Overall (in.)	52 1/8"	Total Amperes	13.9	Width	60"
Depth, Overall (with handle)	38 5/8"	NEMA Plug (8' cord)	5-20P	Depth	45"
Height Overall (6" legs)	84 1/8"	REFRIGERATION DATA		Crated Weight	647 lbs
Depth, Door Open 90°	83 7/8"	Condensing Unit Size, HP	(2) 3/4	*NOTE: Remote units are field wired and comes with 6" legs. Refrigerant must be specified at time of order.	
Door Opening (in.)	21 1/2" x 25 1/4"	Refrigerant*	R-290		
No. Of Doors/Shelves	8/6	Capacity (BTU/HR) (100°F/20°F)	4900		
		Heat Rejection (BTU/HR)	7350		
		Charge (lbs/grams)	0.2866/130		

3779 Champion Blvd, Winston-Salem, NC 27105 | ph: (888) 845-9800 | fax: (800) 253-5168

Sales@VictoryRefrigeration.com | VictoryRefrigeration.com

Rev. 9/30/21 Printed in U.S.A.

an Ali Group Company



The Spirit of Excellence