



# ELECTRIC LEG-MOUNTED TWIN TILTING MIXER KETTLES

- ELTM-40-2
- ELTM-60-2
- ELTM-80-2
- ELTM-100-2

### OPERATION SHALL BE BY:

Electrically, self-generating closed steam system equipped for operation on:

- 208 Volts, 3 Phase, 60 Hz
- 240 Volts, 3 Phase, 60 Hz



### OPTIONS & ACCESSORIES AT ADDITIONAL COST

- |  |  |   |
|--|--|---|
| <input type="checkbox"/> Swing faucet on left or right console | <input type="checkbox"/> 440, 460 or 480 VAC, 60 Hz, 3 Phase     | <input type="checkbox"/> Etched litre markings (LM-)  |
| <input type="checkbox"/> 3" manual butterfly valve (BV-2)      | <input type="checkbox"/> 575 or 600 VAC, 60 Hz, 3 Phase (not UL) | <input type="checkbox"/> MMO motors (specify voltage) |
| <input type="checkbox"/> 2" manual butterfly valve (BV-3)      | <input type="checkbox"/> Two piece lift off cover (MC-)          | <input type="checkbox"/> Pour lip strainer (TKS-)     |
| <input type="checkbox"/> 33 KW elements                        | <input type="checkbox"/> Strainer for butterfly valve (MKS)      | <input type="checkbox"/> Kettle heat shield (KHS-)    |
| <input type="checkbox"/> 380 or 415 VAC, 50 Hz, 3 Phase        | <input type="checkbox"/> Etched gallon markings (GM-)            |   |

### STANDARD CONSTRUCTION SPECIFICATIONS

Shall be a Crown model ELTM-40-2, ELTM-60-2, ELTM-80-2 or ELTM-100-2, self-generating, twin electric kettle.

Construction shall be welded stainless steel type 304 satin finish.

A double wall kettle interior shall form a steam jacket around the lower 2/3 of the kettle, 316 stainless steel liner for high acid content products.

The bottom of the kettle shall be of hemispheric design for maximum heat transfer.

The tubular legs shall be constructed of stainless steel pipe fitted with four hole, adjustable, flanged feet for securing to the floor.

A sealed stainless steel tilt mechanism shall permit the kettle to tilt forward a full 90° for complete emptying.

The tilt mechanism shall be self locking for positive stop action.

Kettle controls shall include a power switch, thermostat, power "on" light (pilot light) vacuum/pressure gauge, pressure relief valve and low water shut off.

Thermostat range to be 140°F to 285°F (60°C to 140°C), a maximum pressure of 50 psi (345 kPa).

Electric elements to be removable.

### MIXER FEATURES:

The mixer is a variable speed unit powered by a 5 hp electric motor driving a hydraulic pump.

Two agitators shall be included, a primary stainless steel scraper/agitator, and a secondary high speed mixer.

Both agitators shall be removable for cleaning and no tools will be required for removal.

The console front to have the main power switch, mixer lift switch and variable speed control.

The bridge is constructed of 10 gauge stainless steel and contains two heavy duty hydraulic motors to drive the agitators.

The bridge shall be power tilt, and swing 140° out of the way for kettle tilting or cleaning.



Approval Notes: \_\_\_\_\_

\_\_\_\_\_

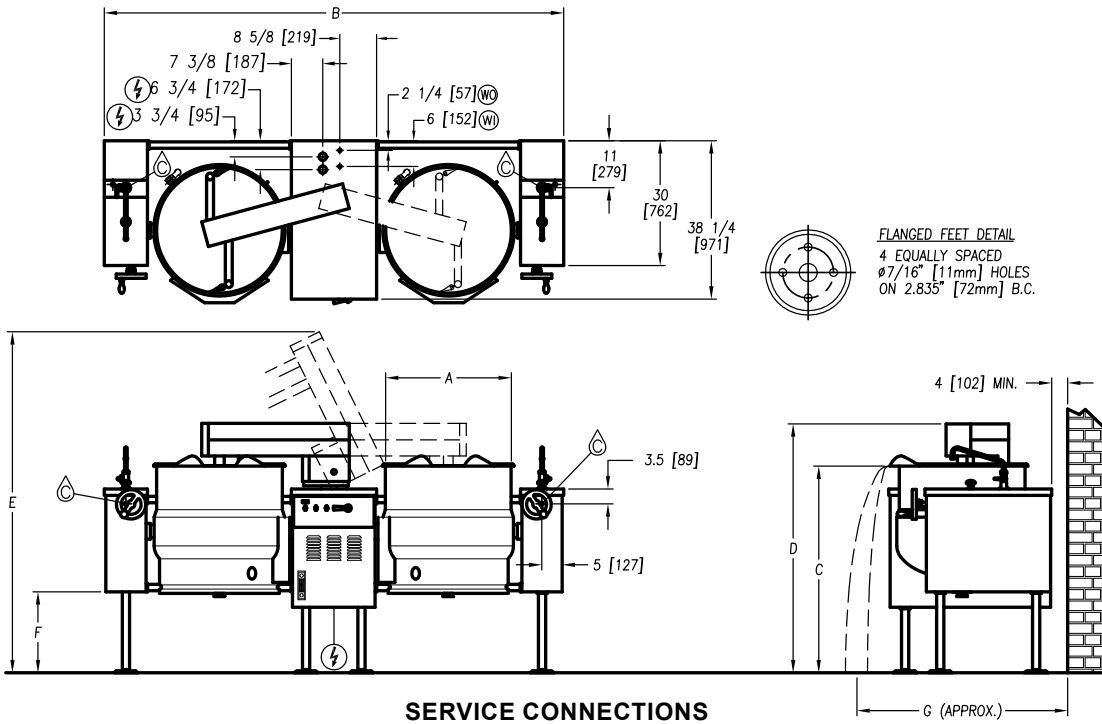

- SERVICE CONNECTIONS**
- C – COLD WATER: 3/8" (10mm) nominal tubing to kettle fill faucet (Optional)
  - ELECTRICAL CONNECTION: As specified by data plate
  - OIL COOLER WATER IN: 3/8" (10mm) Tube bulkhead Union
  - OIL COOLER WATER OUT: 3/8" (10mm) Tube bulkhead Union

**DIMENSIONS**

MODEL	CAPACITY	UNITS	A	B	C	D	E	F	G
ELTM-40-2	40 Gal Each (151 liters)	inches (mm)	26" (660)	102" (2591)	45.5" (1156)	55" (1397)	75.63" (1921)	15.13" (384)	56" (1422)
ELTM-60-2	60 Gal Each (227 liters)	inches (mm)	29.5" (749)	108" (2743)	49" (1245)	58.5" (1486)	80" (2032)	19.5" (495)	58" (1473)
ELTM-80-2	80 Gal Each (303 liters)	inches (mm)	33" (838)	116" (2946)	49" (1245)	58.5" (1486)	80" (2032)	19.5" (495)	60" (1524)
ELTM-100-2	100 Gal Each (380 liters)	inches (mm)	35.5" (902)	121" (3073)	49" (1245)	58.5" (1486)	85" (2159)	19.5" (495)	63" (1600)

**ELECTRICAL CHARACTERISTIC**

MODEL	208V		240V		480V	
	kW	AMP	kW	AMP	kW	AMP
ELTM-40-2	24	147.2	24	129.6	24	64.8
ELTM-60-2						
ELTM-80-2	33	197.4	33	172.8	33	86.4
ELTM-100-2						

**SPECIFICATIONS**

MODEL	CAPACITY	
ELTM-40-2	2 x 40 Gallon	2 x 152 Liter
ELTM-60-2	2 x 60 Gallon	2 x 227 Liter
ELTM-80-2	2 x 80 Gallon	2 x 303 Liter
ELTM-100-2	2 x 100 Gallon	2 x 380 Liter

MODEL	SHIPPING WEIGHT	MINIMUM CLEARANCE	
ELTM-40-2	1600 lbs. [727 kg]	SIDES BACK	3" [ 76 mm] 4" [ 102 mm]
ELTM-60-2	1650 lbs. [705 kg]		
ELTM-80-2	1850 lbs. [840 kg]		
ELTM-100-2	2150 lbs. [975 kg]		

**INTENDED FOR COMMERCIAL USE ONLY.  
NOT FOR HOUSEHOLD USE.**

