

# SOLID SLIDE LID GLASS & PLATE CHILLER

Project Name: \_\_\_\_\_

Project Location: \_\_\_\_\_

Model #: \_\_\_\_\_ Quantity: \_\_\_\_\_

Available Warehouse: \_\_\_\_\_

## EGC Series Model: EGC65



### Refrigeration System

- Bottom mounted, self-contained and retractable condensing unit uses environmentally friendly, EPA compliant R290 refrigerant with zero (0) Ozone Depletion Potential (ODP) and three (3) Global Warming Potential (GWP). Blizzard R290 is easily replaceable and require no on-site brazing.
- Electronically commutated (ECM) fan motors achieve rapid cooling with less energy consumption.
- Full-length air duct system ensures optimal circulation of cold air.
- Time-initiated and temperature-terminated defrost cycle with defrost heater.
- Large capacity, corrosion-resistant condenser and evaporator coils.
- Self-maintaining, energy-efficient condensate drain pan requires no external drains or electric heaters.
- High performance, auto-reverse condenser fan motor supports compressor ventilation and condenser coil cleaning. Refer to owner's manual for full maintenance instructions.
- Pre-wired and ready to plug, 115V/60Hz/1Ph, NEMA 5-15P.

### Cabinet Construction

- Heavy duty stainless steel countertop and rails with textured laminate, black vinyl exterior.
- Open spaced interior with no walls between compartments.
- Galvanized steel interior.
- 1 3/4" thick high density polyurethane insulation.
- Built-in caster thread receptacles for all models.

### Lighting

- Shielded LED bar lighting with on/off switch provides bright, high color illumination at lower heat output.

### Lids

- Heavy duty stainless steel exterior and galvanized steel interior.
- 3/4" thick high density polyurethane insulation.
- Removable ratchet locks keep your items safe from theft.

### Shelving

- Two levels of epoxy coated, steel wire shelves slide horizontally for easy storage of glasses and plates (see table for quantity).

### Temperature Control

- Multi-function digital controller with easy to read LED display.
- Factory preset temperature, -4°F.
- Temperature setting range from -10°F to 54°F.
- Audible overheat protection alarm for compressor and condenser coil.

### Options

- 3" or 5" swivel casters with locks.
- 3.5" – 6" height-adjustable and interchangeable legs.

 **Operating temperature range is -10°F ~ 54°F**



**5 YEAR Compressor  
3 YEAR Parts & Labor**



Please visit our website for updated Energy Efficiency information

Ref/ Frz/Dual	Lids	Capacity		Shelves	Refrigerant	HP	Power V-Hz-Ph	Amps	Crated Weight	Exterior Dimensions		
		Cu. Ft.	(8") Mugs							L	D	H*
FRZ	2	21	290	7	R-290	1/2	115-60-1	5	314 lbs (142kg)	64.625" (1641mm)	26.75" (679mm)	33.75" (857mm)

(†) Based on evaporating temperature of 23°F (-5°C) & condensing temperature of 131°F (55°C). (►) Product capacity is calculated based on standard industry figures. (✳) Reference plan view for clarification on caster/unit height. If dimensions and capacity are critical, please contact Everest Refrigeration. Blizzard R290 replacement is at the sole discretion of Everest Refrigeration. Specifications subject to change without notice.

# SOLID SLIDE LID GLASS & PLATE CHILLER

## EGC Series Model: EGC65

### DIMENSIONAL DATA

External Dimensions	L	64.625" (1641mm)
	D	26.75" (679mm)
	H*	33.75" (857mm)
Crated Weight		314 lbs. (142kg)
Doors/Drawers/Lids		2
Max Weight Support (LBS)		-

### STORAGE DATA

Net Capacity Cu. Ft. ▶	21
Shelves	7
Barrels	-
20 oz. Bottles	-
12 oz. Bottles	-
12 oz. Cans	-
8" Mugs	290
# of Pans (Top)	-
# of Pans (Drawer)	-
Dividers	-
Trays	-

### ELECTRICAL DATA

Voltage	115-60-1
Full Load Amperage	5A
Feed Wires with Ground	3
Cord Length	9ft
NEMA Plug Type	 NEMA 5-15P

### REFRIGERATION DATA

Compressor Mounting	Side
Refrigerant	R-290
Compressor HP	1/2
BTU/HR †	1979

### KEY

D	Door	R	Refrigerator
L	Lid	REF	Refrigerator
H	Half Door	F	Freezer
FD	Full Door	FRZ	Freezer
SD	Solid Door	DUAL	REF/FRZ Combo
GD	Glass Door	DR	Drawer

	Elevation	Right	Plan	3D	Back

### PLAN VIEW

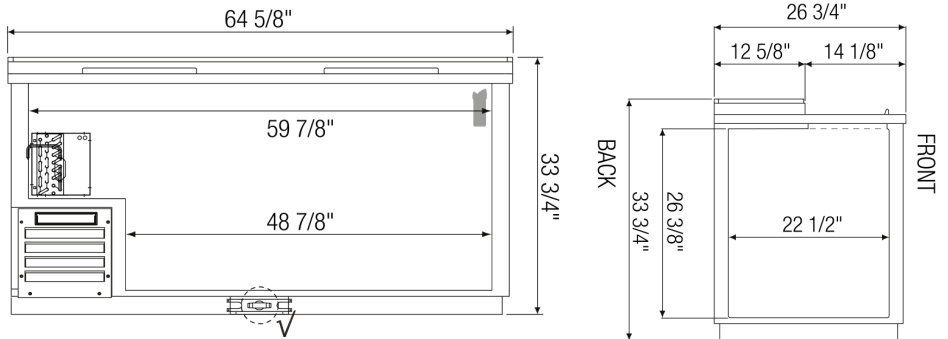

FRONT

SIDE

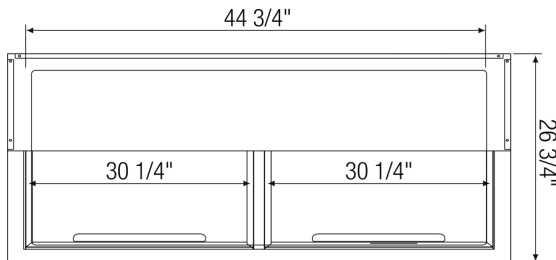

TOP

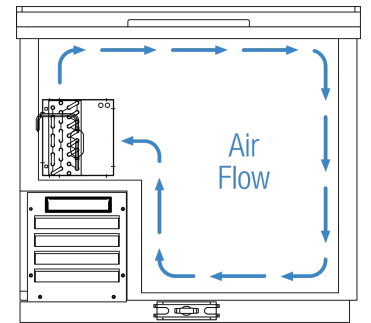

AIRFLOW

### ACCESSORIES & OPTIONS

Part Number	Description
AJL03-00	Interchangeable Leg for Caster
CASA3-01	3" Overall Height Caster Assembly - (2) Front (2) Rear
CASA5-01	5" Overall Height Caster Assembly - (2) Front (2) Rear

(†)Based on evaporating temperature of 23°F (-5°C) & condensing temperature of 131°F (55°C). (▶) Product capacity is calculated based on standard industry figures. (✖) Reference plan view for clarification on caster/unit height. If dimensions and capacity are critical, please contact Everest Refrigeration. Blizzard R290 replacement is at the sole discretion of Everest Refrigeration. Specifications subject to change without notice.