



Profit from the Eagle Advantage®

Specification Sheet

Short Form Specifications

Eagle Stainless Steel Caster Cradle® caster stabilizing device, model # _____. Conforms to NFPA 17A 5.6.4 requirements for stabilizing cooking equipment and correct placement under fire system nozzles. Unique bowl shaped design allows for accurate placement of mobile equipment every time. Units are secured to the floor where the casters are to be centered.

Item No.:	_____
Project No.:	_____
S.I.S. No.:	_____

Stainless Steel Caster Cradle® Stabilizing Device

MODELS:

- CC-S-2
- CC-S-10
- CC-S-60



Design and Construction Features

- Designed to conform to requirements of NFPA 17A 5.6.4 for stabilization of cooking equipment and correct placement under fire system nozzles, using a set of two (typically), placed at rear wheels of equipment with front locking casters.
- When the caster wheel enters anywhere along the edge of the caster cradle, gravity will cause it to drop automatically to the direct center, assuring exact placement of mobile equipment every time.
- Low profile design allows for easy movement of equipment caster into the contoured center.
- Circular design allows approach from any angle, making equipment alignment easy.
- Easy installation in any existing kitchen.
- Works with casters from 4" to 8" (76 to 203mm)-diameter.
- Heavy gauge stainless steel.
- Can be used to keep any mobile equipment properly aligned throughout the kitchen.

EAGLE GROUP
 100 Industrial Boulevard, Clayton, DE 19938-8903 USA
 Phone: 302-653-3000 • Fax: 302-653-2065
 www.eaglegrp.com

Foodservice Division: Phone 800-441-8440
MHC/Retail Display Divisions: Phone 800-637-5100

For custom configuration or fabrication needs, contact our **SpecFAB® Division**.
 Phone: 302-653-3000 • Fax: 302-653-2065 • e-mail: quotes@eaglegrp.com



EG30.21 Rev. 06/18

Spec sheets available for viewing, printing or downloading from our online literature library at www.eaglegrp.com



Item No.: _____
 Project No.: _____
 S.I.S. No.: _____

Stainless Steel Caster Cradle® Stabilizing Device

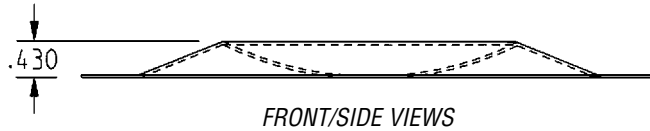
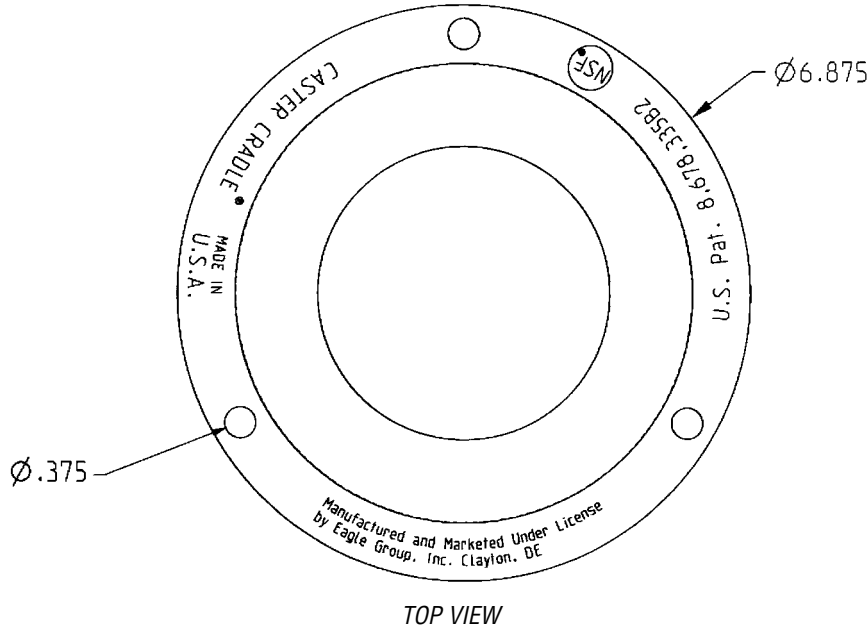

model #	description	weight	
		lbs.	kg
CC-S-2	quantity of two per package	1	0.5
CC-S-10	quantity of 10 per package	4	1.8
CC-S-60	quantity of 60 per package	23	10.4

EAGLE GROUP
 100 Industrial Boulevard, Clayton, DE 19938-8903 USA
 Phone: 302-653-3000 • Fax: 302-653-2065
 www.eaglegrp.com

Foodservice Division: Phone 800-441-8440
 MHC/Retail Display Divisions: Phone 800-637-5100

Printed in U.S.A.
 ©2018 by Eagle Group
 Rev. 06/18

Spec sheets available for viewing, printing or downloading from our online literature library at www.eaglegrp.com

Although every attempt has been made to ensure the accuracy of the information provided, we cannot be held responsible for typographical or printing errors. Information and specifications are subject to change without notice. Please confirm at time of order.