



Job _____ Item No. _____

Notes: _____

Floor Model Reversible Sheeter

Model Number: LMA620 LMA624 LMA630

Reversible Sheeter

SPECIFICATIONS



Shown in Optional S/S Construction

DESCRIPTION

The LMA Series Reversible Sheeters are ideal for production areas that handle doughs from cookie to croissant. Simple to operate, easy to clean, and folds to store freeing up more workspace. Our bench model sheeter is designed for consistency and labor cost savings.

SHORT FORM SPECIFICATIONS

Reversible Sheeter, Floor Style, Electric, Adjustable Belt Thickness from 1/32" to 1 1/2", 20 Adjustable Speed Settings, 30 LB Dough Capacity, Polyurethane Belts, Folds for Storage, Thermal overload protection for motor, Stainless Steel Rollers, Flour Reservoir Above Rollers, 78 3/4" Wide Conveyor on LMA620 & 94 1/2" on the LMA624 & 118 1/8" on LMA630, Wire guard for Rollers Featuring Motor Cutoff Switch, Catch Pan on Each End of Belt, 3/4 HP Motor, One year labor and two year parts

WARRANTY

The LMA620, LMA624 & LMA630 both come with a one year warranty for parts and two year warranty for labor.

FEATURES

- Folds Up for Easy Storage
- 20 Adjustable Speeds
- Flour Reservoir Above Rollers
- Stainless Steel Catch Pans on End of Each Belt
- Synchronized Belt System
- Adjustable Thickness from 1/32" to 1 1/2"
- Control Belts by either the Dual Hand Controls for Forward and Reverse on Each Side, or the Floor Pedals
- Emergency Stop
- Easy to Remove and Adjust Scrapers
- Stainless Steel Rollers
- Polyurethane Belts
- Protective Guards with Motor Shutoff Feature
- Low Profile Casters to Move As Needed

OPTIONS AND ACCESSORIES

- Stainless Steel Construction (Suffix I)
- Croissant Cutter for LMA630 -
For (3) 6 1/2" Wide Croissants (CPL001 & RCM001)
For (4) 5" Wide Croissants (CPL002 & RCM001)

CERTIFICATIONS

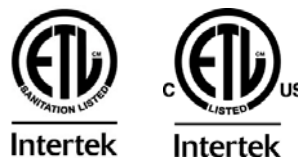

Doyon/NU-VU

5600 13th Street, Menominee, MI 49858

Phone 800.338.9886 • Fax 906.863.5889

www.doyon.qc.ca

Follow Us





SPECIFICATIONS

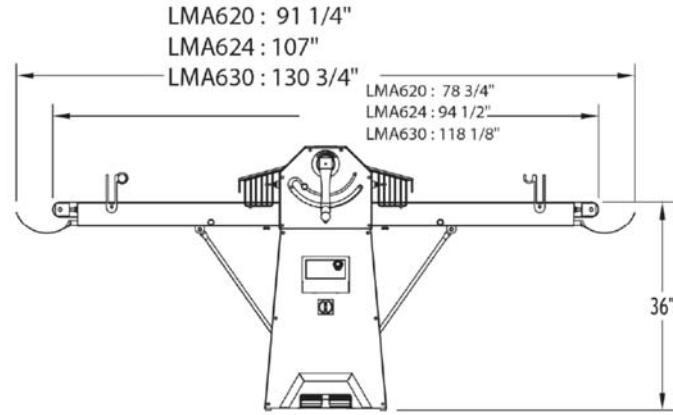
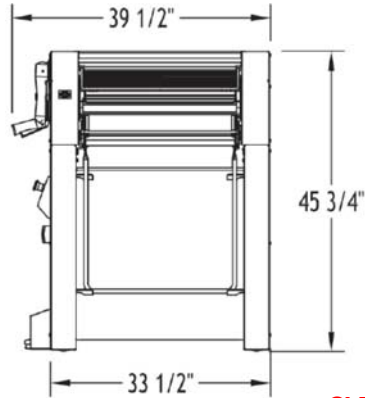
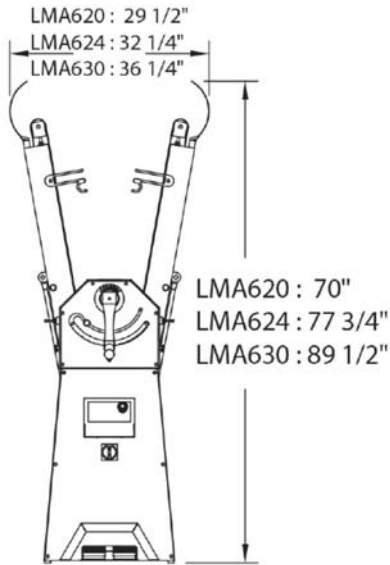

CLEARANCES

A clearance of at least 6" (152mm) must be maintained around sides. Do not place anything directly underneath the belts.

ELECTRICAL DATA

Single electrical connection, 120V, 993 watts, 8.3A, 60Hz, single phase, NEMA 5-15P plug.

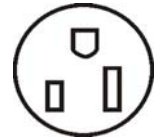

Model	Conveyor Dimensions				Motor (HP)	Height [A]		Depth [B]		Width [C]		Weight	
	D		W			in	mm	in	mm	in	mm	lbs	kg
	In	mm	In	mm									
LMA620	23	584	78 3/4	2000	3/4	45 3/4	1162	39 1/2	1005	91 1/4	2318	570	258
LMA624	23	584	94 1/2	2400	3/4	45 3/4	1162	39 1/2	1005	107	2718	595	269
LMA630	23	584	118 1/8	3000	3/4	45 3/4	1162	39 1/2	1005	130 3/4	3321	645	292

Due to periodic changes in designs, methods, procedures, policies and regulations, the specifications contained in this sheet are subject to change without notice. While Doyon/NU-VU exercises good faith efforts to provide information that is accurate, we are not responsible for errors or omissions in information provided or conclusions reached as a result of using these specifications. By using the information provided, the user assumes all risks in connection with such use.

Doyon/NU-VU

5600 13th Street, Menominee, MI 49858
 Phone 800.338.9886 • Fax 906.863.5889
 www.doyon.qc.ca



Printed in the USA • LMA • Rev. A • 03.2021
 Specifications are subject to change without notice and are not intended for installation purposes.