

# DESIGNER LINE WARMER

**Model: DL3W-HD**

*Designer Line*

## 3-Section Reach-In Warmer with Half Doors

DL3W-HD - Stainless steel front, aluminum end panels and interior  
 DL3W-SA-HD - Stainless steel exterior, aluminum interior  
 DL3W-SS-HD - Stainless steel exterior and interior



### Options and Accessories

(upcharge and lead times may apply)

Stainless steel case back	Glass doors
Add'l chrome-plated steel shelves	Pass-Thru
Stainless steel shelves	Special electrical req. (consult factory)
Rehinging of doors (consult factory)	<b>Correctional Facility Options</b>
Pan slide assemblies	<ul style="list-style-type: none"> <li>One way security screws</li> </ul>
Casters	<ul style="list-style-type: none"> <li>Locking hasp (lock not included)</li> </ul>
Custom laminates	<ul style="list-style-type: none"> <li>Stainless steel mesh cover</li> </ul>
Full doors	<ul style="list-style-type: none"> <li>Coverless hinges</li> </ul>

Consult factory for other model configurations, options and accessories.

Project Name:

Model Specified:

Location:

Item No:

Quantity:

AIA #:

SIS #:

### Standard Model Features

#### HEATING SYSTEM

Self contained, performance-rated heating system  
 90°F to 180°F temperature range  
 Top mounted heating plenum "plug" w/circulating fan  
 Unique air flow distribution ducts

#### CABINET ARCHITECTURE

3" non-CFC polyurethane foam insulation  
 Smooth, polished chrome workflow door handles  
 Cam action, lift off hinges  
 Self-closing doors  
 Magnetic snap-in door gaskets  
 Cylinder lock in each door  
 (9) heavy-duty, chrome-plated steel shelves  
 Adjustable 6" stainless steel legs

#### MODEL FEATURES

Automatic interior lighting  
 Electronic controller w/digital display & hi-low alarm  
 Stainless steel strip heaters located in base of interior

**Continental**  
 Refrigerator

Toll-Free: 800-523-7138  
 Phone: 215-244-1400  
 Fax: 215-244-9579

539 Dunksferry Road  
 Bensalem, PA 19020  
[www.continentalrefrigerator.com](http://www.continentalrefrigerator.com)

APPROVAL:

## Model Specifications

### DIMENSIONAL DATA

Net Capacity (cu. ft.)	72 (2039 cu l)
Width, Overall (in.)	78 (1981 mm)
Depth, Overall (in.) (incl. handles)	35 3/8 (899 mm)
Depth (in.) (less doors)	32 (813 mm)
Depth (in.) (doors open 90°)	55 1/2 (1410 mm)
Clear Door Width (in.)	19 3/8 (492 mm)
Clear Half Door Height (in.)	27 1/2 (699 mm)
Height, Overall (in.) (incl. 6" legs)	83 1/4 (2115 mm)
No. of Doors	3
No. of Shelves	9
Shelf Area (sq. ft.)	61.2 (5.7 sq m)
Tray Slide Capacity (per top sections)	9
Tray Slide Capacity (per bottom sections)	6

### ELECTRICAL DATA

Voltage	208-230/60/1
Feed Wires (incl. ground)	3
Total Amps (int'l)	13.9 (13.9)
Total Wattage @ 208-230 volts	3000
10 ft. Cord/Plug (int'l)	No (No)

### SHIPPING DATA

Height - Crated (in.)	85 1/2 (2172 mm)
Width - Crated (in.)	90 (2286 mm)
Depth - Crated (in.)	42 (1067 mm)
Volume - Crated (cu. ft.)	187 (5295 cu l)
Weight Std - Crated (lbs.)	650 (295 kg)
Weight SS - Crated (lbs.)	685 (311 kg)

Figures in parentheses reflect metric equivalents rounded to the nearest whole unit.

## Model Plan Views

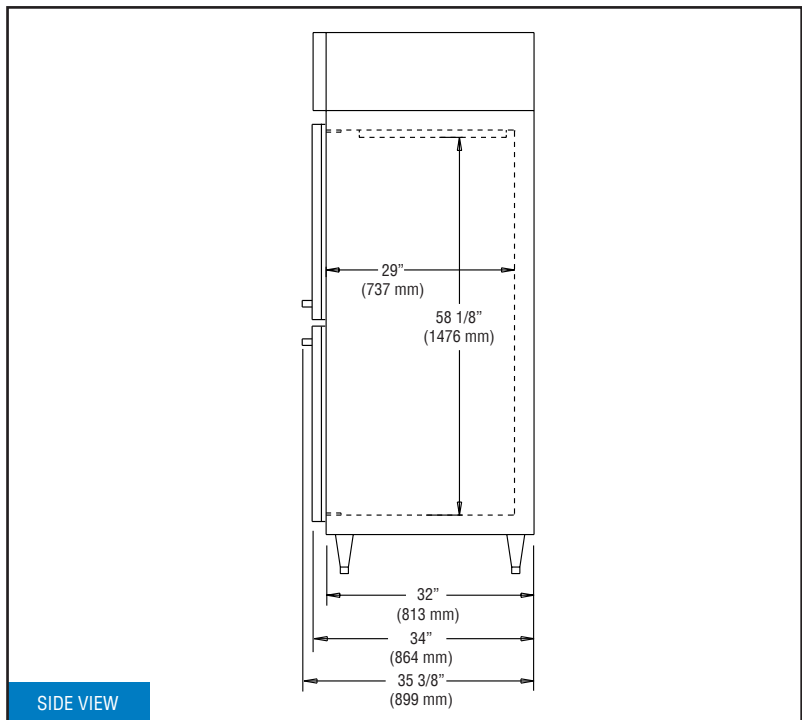
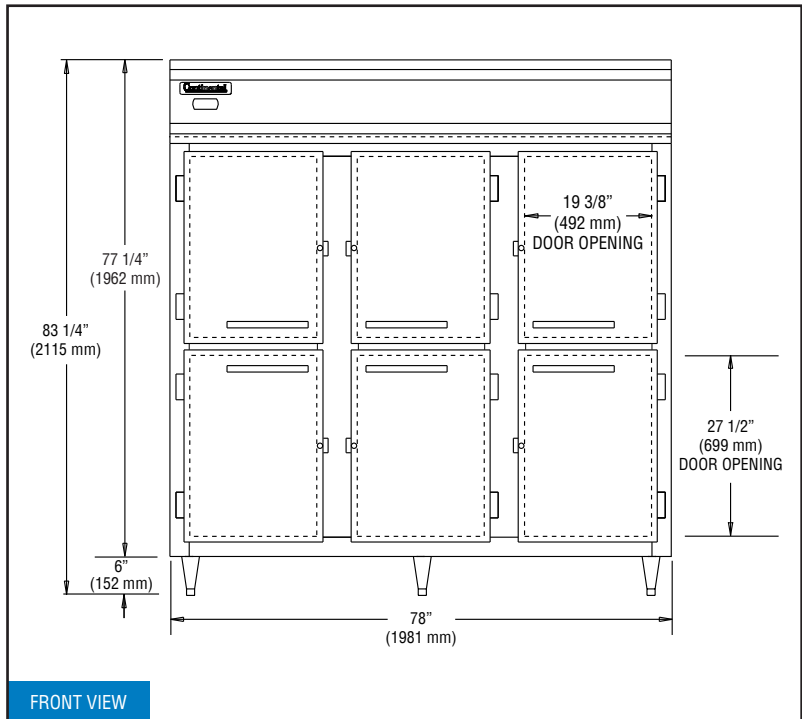

**IMPORTANT NOTE:** If the cabinet is located directly against a wall and/or under a low ceiling, a minimum clearance of 12" is required on top and 3" on sides and rear.

**Continental**  
Refrigerator

Toll-Free: 800-523-7138  
Phone: 215-244-1400  
Fax: 215-244-9579

539 Dunksferry Road  
Bensalem, PA 19020  
[www.continentalrefrigerator.com](http://www.continentalrefrigerator.com)

Due to our continued efforts in developing innovative products, specifications subject to change without notice.



Intertek



MADE IN THE U.S.A.

© Copyright 2019, Continental Refrigerator.  
A Division of National Refrigeration & Air Conditioning Products, Inc.