

DESIGNER LINE WARMER

Model: DL1WE-PT

Designer Line

1-Section Extra-Wide Pass-Thru Warmer

DL1WE-PT - Stainless steel front, aluminum end panels and interior
DL1WE-SA-PT - Stainless steel exterior, aluminum interior
DL1WE-SS-PT - Stainless steel exterior and interior



Project Name:

Model Specified:

Location:

Item No:

Quantity:

AIA #:

SIS #:

Standard Model Features

HEATING SYSTEM

Self contained, performance-rated heating system
 90°F to 180°F temperature range
 Top mounted heating plenum "plug" w/circulating fan
 Unique air flow distribution ducts

CABINET ARCHITECTURE

3" non-CFC polyurethane foam insulation
 Smooth, polished chrome workflow door handles
 Cam action, lift off hinges
 Self-closing doors
 Magnetic snap-in door gaskets
 Cylinder lock in each door
 (3) heavy-duty, chrome-plated steel shelves
 Adjustable 6" stainless steel legs

MODEL FEATURES

Automatic interior lighting
 Electronic controller w/digital display & hi-low alarm
 Stainless steel strip heaters located in base of interior

Options and Accessories

(upcharge and lead times may apply)

Stainless steel case back	Glass doors
Add'l chrome-plated steel shelves	Special electrical req. (consult factory)
Stainless steel shelves	Correctional Facility Options
Rehinging of doors (consult factory)	<ul style="list-style-type: none"> One way security screws
Pan slide assemblies	<ul style="list-style-type: none"> Locking hasp (lock not included)
Casters	<ul style="list-style-type: none"> Stainless steel mesh cover
Custom laminates	<ul style="list-style-type: none"> Coverless hinges
Half doors	

Consult factory for other model configurations, options and accessories.

Continental
 Refrigerator

Toll-Free: 800-523-7138
 Phone: 215-244-1400
 Fax: 215-244-9579

539 Dunksferry Road
 Bensalem, PA 19020
www.continentalrefrigerator.com

APPROVAL:

Model Specifications

DIMENSIONAL DATA

Net Capacity (cu. ft.)	22 (623 cu l)
Width, Overall (in.)	28 1/2 (724 mm)
Depth, Overall (in.) (incl. handle)	38 3/4 (984 mm)
Depth (in.) (less door)	32 (813 mm)
Depth (in.) (door open 90°)	84 (2134 mm)
Clear Door Width (in.)	21 7/8 (556 mm)
Clear Door Height (in.)	58 5/8 (1489 mm)
Height, Overall (in.) (incl. 6" legs)	83 1/4 (2115 mm)
No. of Doors	2
No. of Shelves	3
Shelf Area (sq. ft.)	22.2 (2.1 sq m)
Tray Slide Capacity	19

ELECTRICAL DATA

Voltage	208-230/60/1
Feed Wires (incl. ground)	3
Total Amps (int'l)	7.2 (7.2)
Total Wattage @ 208-230 volts	1500
10 ft. Cord/Plug (int'l)	No (No)

SHIPPING DATA

Height - Crated (in.)	85 1/2 (2172 mm)
Width - Crated (in.)	31 5/8 (803 mm)
Depth - Crated (in.)	42 (1067 mm)
Volume - Crated (cu. ft.)	65 (1841 cu l)
Weight Std - Crated (lbs.)	320 (145 kg)
Weight SS - Crated (lbs.)	336 (152 kg)

Figures in parentheses reflect metric equivalents rounded to the nearest whole unit.

Model Plan Views

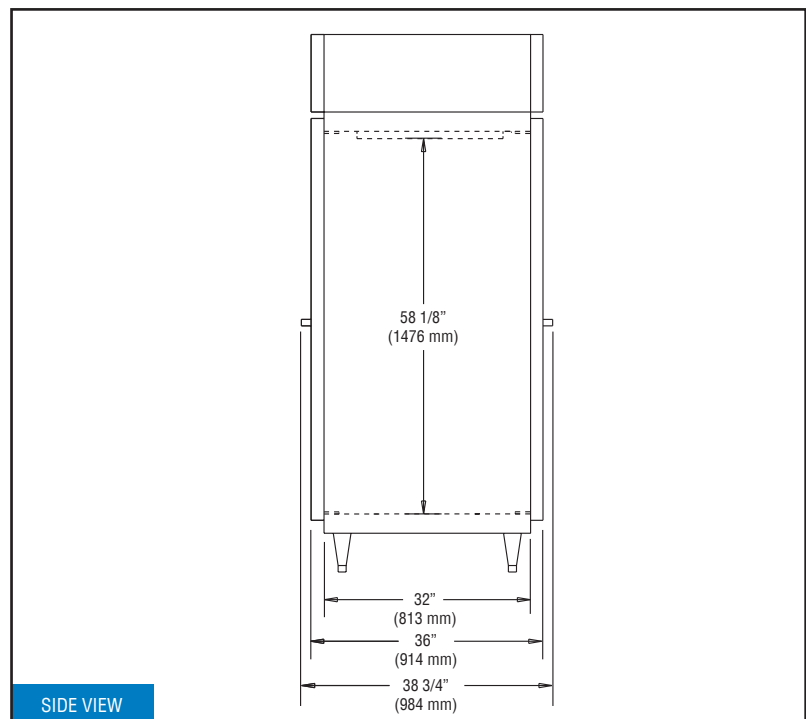
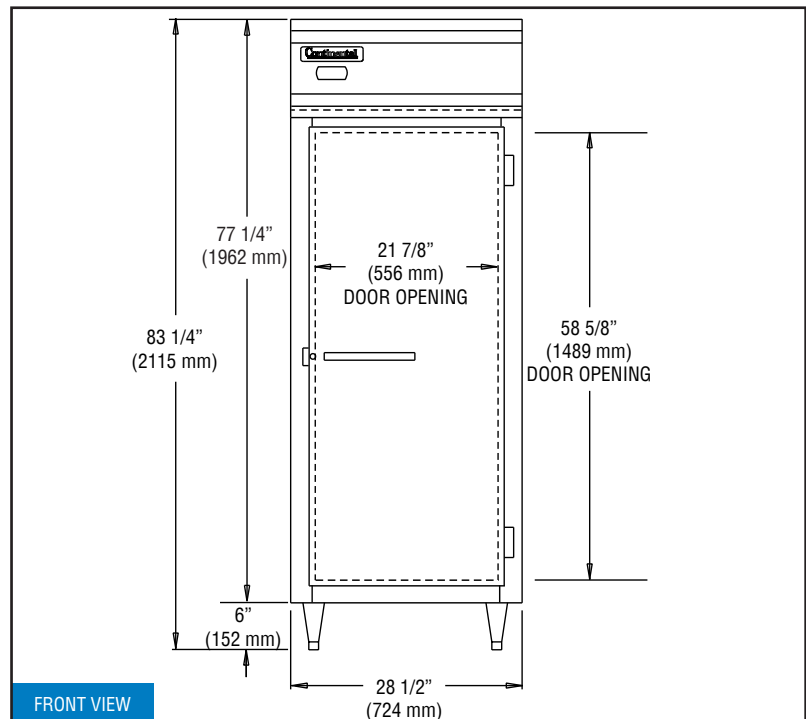

IMPORTANT NOTE: If the cabinet is located directly against a wall and/or under a low ceiling, a minimum clearance of 12" is required on top and 3" on sides and rear.

Continental
Refrigerator

Toll-Free: 800-523-7138
Phone: 215-244-1400
Fax: 215-244-9579

539 Dunksferry Road
Bensalem, PA 19020
www.continentalrefrigerator.com

Due to our continued efforts in developing innovative products, specifications subject to change without notice.



Intertek



MADE IN THE U.S.A.

© Copyright 2019, Continental Refrigerator.
A Division of National Refrigeration & Air Conditioning Products, Inc.