



# TILTING FLOOR KETTLE

## LOW HEIGHT ELECTRIC MODELS DEES-40C/A/C2T

Kettle shall be a Groen Model DEES-40 (specify Classic (C), Advanced (A) or Cook2Temp™ (C2T™) controls) stainless steel low height, floor model tilting, fully steam jacketed unit, operating with an electric heated steam source contained within unit. CookTemp models also come with a probe.

PROJECT NAME:	
LOCATION:	
ITEM NO:	
QTY:	
MODEL NO:	
AIA NO:	
SIS NO:	
CSI SECTION:	

### AVAILABLE MODELS:

#### CLASSIC CONTROLS:

DEES-40C

#### ADVANCED CONTROLS:

DEES-40A

#### COOK2TEMP CONTROLS:

DEES-40C2T

**CONSTRUCTION:** Kettle interior shall be of type 316 stainless steel, with solid one-piece welded construction. All exposed surfaces shall be stainless steel. The kettle body shall be mounted in a heavy-duty stainless steel tilt trunnion. The trunnion assembly is supported by the stainless steel enclosed base. The base shall have stainless steel tubular legs with height adjustable bullet feet. The trunnion enclosure shall contain a smooth operating, self-locking tilt mechanism, with a water resistant IPX6-rated enclosure with interior readily accessible for installation or maintenance. The unit shall have an ergonomic low kettle rim height with heavy reinforced bar rim with a welded-in butterfly shaped pouring lip for pouring control and durability. Faucet mounting bracket is standard. Designed for single point electrical connection.

**FINISH:** Kettle interior shall be polished to a 180 emery grit finish. Exterior of kettle shall be finished to a bright high buff finish, ensuring maximum ease in cleaning and maintaining a brilliant appearance.

### ASME CODE, UL LISTED, CRN REGISTERED:

Unit shall be ASME shop inspected, stamped and registered with the National Board for operation up to a maximum working pressure of 50 PSI. Unit shall be UL listed for sale in USA and Canada. Unit shall be registered in Canada with a CRN number.

**SANITATION:** Unit shall be designed and constructed to meet NSF requirements and be NSF listed.

**DRAWOFF VALVE:** A 2" sanitary tangent drawoff is optional. If drawoff is specified, outlet shall be equipped with removable 1/4" perforated stainless steel strainer.

### SELF-CONTAINED STEAM SOURCE:

Kettle shall have an electrically heated self-contained steam source to provide kettle temperatures of 150°F to approximately 295°F. Unit shall be factory charged with water and rust inhibitor to ensure long life and minimum maintenance.

**CONTROLS:** Controls to be located in right-side water resistant (IPX6-rated) trunnion enclosure:

**Classic -C Models** include: Power ON-OFF switch with indicator light, temperature control knob with 1 to 10 increments, HEAT(ing) indicator light and LOW WATER warning light; **Advanced -A Models** include: Same control features as Classic models with the addition of temperature and time set knob, LED display of set heat level or cook time, buttons for reset of Low Temp and High Temp presets, MANUAL mode button for knob-setting of heat level, TIMER-set button with indicator light; **Cook2Temp -C2T Models** include: Same control features as Classic and Advanced models with the addition of Auto C2T and Manual C2T buttons with core probe connection port, MANUAL mode button for knob-setting of heat level for manual cooking and manual C2T cooking.

**SAFETY SYSTEMS:** Safety systems to include kettle-mounted: pressure-vacuum gauge, pressure relief valve, pressure limit control, water sight glass; plus safety tilt and low-water cutoffs.

**PERFORMANCE FEATURES:** Unit shall be thermostatically controlled to automatically shut off when the desired temperature setting is reached and turn on when product temperature drops below desired setting. Smooth action manual crank tilt allows for easy pouring and transfer of kettle contents. Lower rim height makes inspection, ingredient loading and cleaning easier.

**INSTALLATION:** Specify 208, 240 or 480 Volt, single or three phase, for 60 cycle electric service.

**ORIGIN OF MANUFACTURE:** Designed and manufactured in the United States.



DEES-40C Model shown

### OPTIONS/ACCESSORIES:

- Water fill faucets
- Lift-off cover (No. 31)
- Counterbalanced, spring assist hinged cover kit (No. 51)
- 2" tangent draw-off (TDO) valve with 1/4" perforated strainer
- Solid disk strainer
- 1/4" perforated strainer
- 1/8" perforated strainer
- Contour measuring strip
- Gallon etch marks
- Lip strainer
- Pan carrier
- Kettle brush kit
- Single Phase Terminal Block Kit
- Replacement core probe (on C2T models only)



P/N 175851 REV A

ELECTRICAL REQUIREMENTS TABLE		DEES-40	
KETTLE MODEL	PHASE	KW	AMPS
208	1 PH	21	101
240	3 PH	24	58
480	1 PH	24	50
	3 PH	24	29

TABLE OF DIMENSIONS		40 GALLONS	
DIMS.	INCH	MM	
A	30	762	
B	47	1194	
C	31	787	
D	36 3/8	924	
E	13 1/4	337	
F	38 7/8	987	
G	10 3/8	264	
H	29 1/2	749	
J	29 1/2	749	
K	57 1/2	1460	
L	16 3/4	425	

**NOTES :-**

- OPTIONAL EXTRA COST FEATURES:
  - 2" TANGENT SANITARY DRAW-OFF
  - FAUCET WITH SWING SPOUT
  - MODEL #31 LIFT OFF COVER.
- DIMENSIONS IN BRACKETS ( ) ARE MM.
- CUSTOMER TO SUPPLY WATER RESISTANT CONDUIT FITTING FOR ELECTRICAL SUPPLY.
- USE KIT 170960 IF SWITCHING FROM 3 PHASE TO SINGLE PHASE

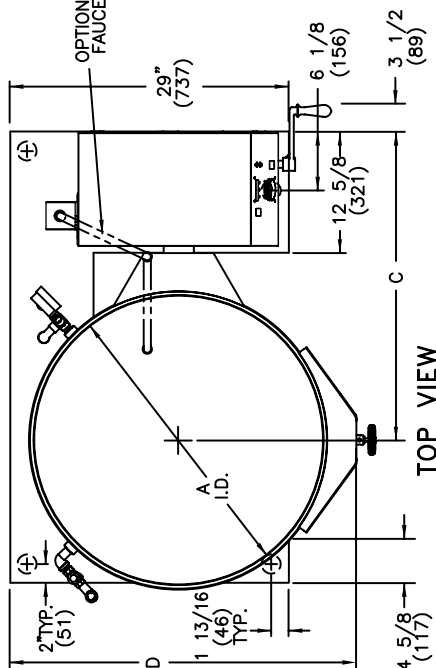

**TOP VIEW**

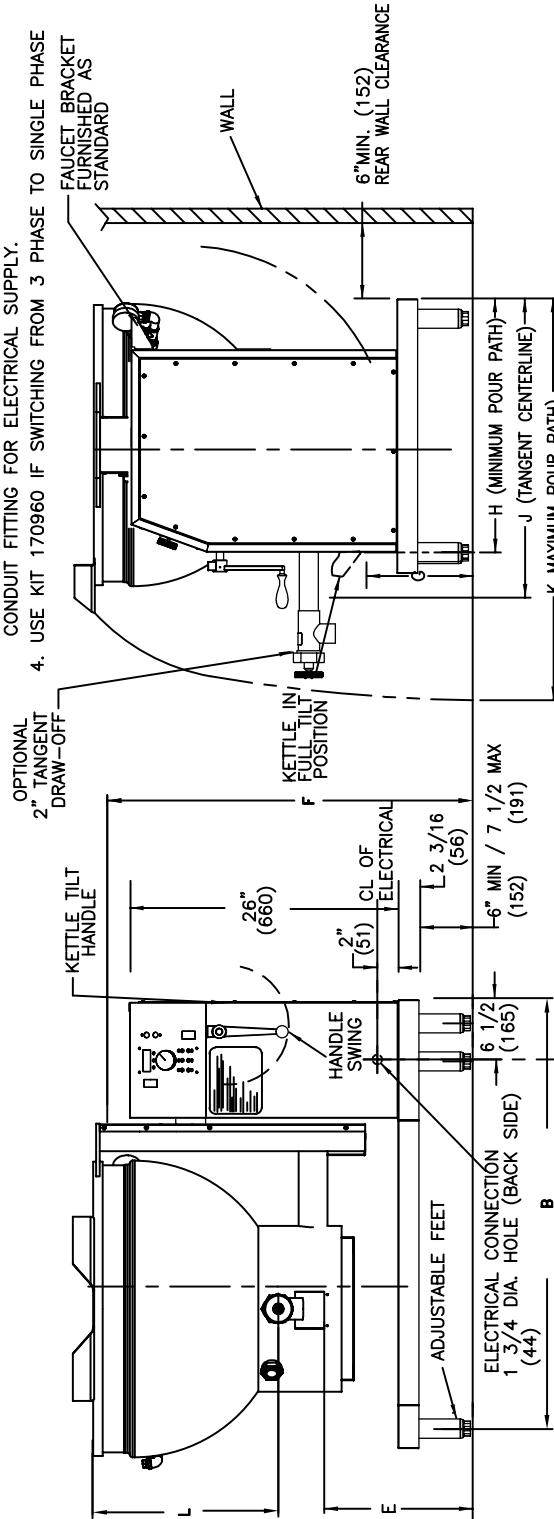

**FRONT VIEW**

**RIGHT SIDE VIEW**



CLASSIC CONTROL



ADVANCED CONTROL



COOK2TEMP CONTROL