



Decathlon Gas Fryer Batteries with Filtration -- Domestic & Export

Project _____
 Item _____
 Quantity _____
 CSI Section 11400 _____
 Approval _____
 Date _____

Models

- SCFD250G SCFD450G SCFD260G SCFD460G
 SCFD350G SCFD550G SCFD360G



SCFD250G

Fryer Standard Features

- Thermo-tube design heat transfer system
- Oil capacity
SCFD50G -- 50-lb. (25 liter)
SCFD60G -- 75-lb (37 liter)
- Btu/hr. input
SCFD50G -- 120,000 Btu/hr. (30,600 kcal) (35.2 kw)
SCFD60G -- 150,000 Btu/hr. (37,783 kcal) (44 kw)
- Frying area
SCFD50G -- 14" x 14" x 3-1/2" (35 x 35 x 8.9 cm)
SCFD60G -- 18" x 18" x 3-3/4" (46 x 46 x 9.5 cm)
- Thermatron controller
- Robust, RTD, 1° compensating temperature probe
- Stainless-steel frypot, door, front and sides
- Two twin baskets per frypot
- Gas connection -- see chart on back
- Combination gas valve with regulator
- Wide cold zone
- Melt cycle and boil-out mode
- Casters
- Drain safety switch

Filter Standard Features

- Space-saving filter fits inside fryer cabinet which houses two or more frypots or one frypot and spreader
- Large capacity filter pan removes easily for cleaning
- Sloped drain pan leaves minimal oil in the pan after filtering
- Large 3" (8.0 cm) round drain line allows oil to drain freely
- Filter cycle is complete from start to finish in under 5 minutes, while other frypots in the system are in use
- Filters all fryers in the battery
- Rear oil flush
- 1-1/4" (3.2 cm) diameter, one-point end connection, rear manifold gas line without shut-off valve
- 1/3 H.P. filter motor
- 4 GPM pump (15 LPM)
- Stainless steel crumb catcher
- Filter starter kit
- Casters

Specifications

Designed for high-volume frying and controlled performance

High-production cooking capacity and fast recovery meet high-volume frying needs. Oil capacities of these units make them ideal for everything from French fries to large-size menu items requiring more frying area.

A larger heat-transfer area reduces the heat per square inch needed to attain and maintain desired cooking temperatures, which reduces the oil's heat load and therefore the breakdown of the oil. Stainless steel baffles and reliable, built-to-last burners keep maintenance to a minimum. Precise temperature control during heat-up and recovery protects oil from excessive high-heat damage. The wide cold zone traps sediment away from the cooking area, safeguarding oil quality and the quality of the food.

High-production cooking capacity and fast recovery meet high-volume frying needs.

Dean's renowned, built-in filtration system puts filtration where it's most convenient to use -- right within the fryer battery -- eliminating the need for additional floor and storage space.

The filtering process is fast and easy, encouraging frequent filtering -- a critical part of maximizing oil life, especially with trans-fat free oils. It is also sequential, so one fryer may be filtered while the others are still in use. It is engineered with features that allow added convenience and ease of use.

This system is enhanced with a gravity draining system that allows residual oil to drain into the filter pan so that drain lines are always open. The filter, housed beneath two Dean fryers or one fryer and a spreader, is capable of filtering up to six fryers, individually, without having to be moved from fryer to fryer, saving valuable labor. Oil can be filtered quickly while other fryers in the battery continue cooking.

This filter comes standard with a powerful 4 GPM pump to maximize filtering efficiency and minimize clogging. Large sump with secure hold-down ring ensures proper vacuum and superior oil filtration. The stainless steel filter pan is equipped with casters and an automatic connection for ease of access.

Filtration process is two steps:

Step one: open drain valve, open return valve to activate filter pump.

Step two: close drain valve; close return valve to turn off pump.



8700 Line Avenue
 Shreveport, LA 71106
 USA

Tel: 318-865-1711
 Tel: 1-800-221-4583
 Fax: 318-868-5987
 E-mail: info@frymaster.com

www.frymaster.com
 Bulletin No. 830-0043
 Revised 5/20/16



Decathlon Fryer Batteries with Filtration -- Domestic & Export



Decathlon Fryer Batteries with Filtration -- Domestic & Export

Model # _____
CSI Section 11400

OPTIONS & ACCESSORIES

- External oil discharge -- available on built-in filter batteries with 2 or more frypots -- must specify front or rear connection
- 8 GPM (15 LPM) pump
- Drain safety switch
- Spreader cabinet(s) -- SCFD50 models must fit within a 5-cabinet fryer battery; SCFD60 models must fit within a 4-cabinet fryer battery
- Frypot covers
- Full basket
- Triplet basket
- Chicken basket
- Crisper tray
- Sediment tray
- Front work shelf
- Splash shield

POWER REQUIREMENTS

MODEL NO.	OPTIONS DOMESTIC/EXPORT	
	CONTROLS/FRYPOT	FILTER
D150G	120V 1 A	120V 8 A
D160G	220 - 240V 1 A	220 - 240V 4 A

8700 Line Avenue
Shreveport, LA 71106
USA

Tel: 318-865-1711
Tel: 1-800-221-4583
Fax: 318-868-5987
E-mail: info@frymaster.com

www.frymaster.com
Bulletin No. 830-0043
Revised 5/20/16



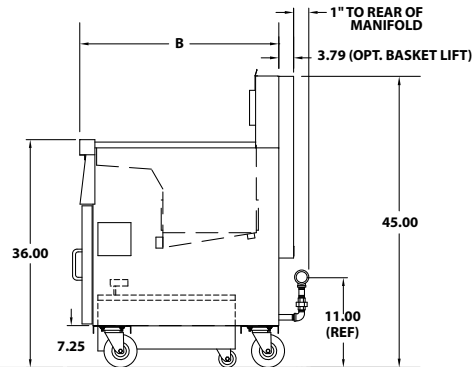
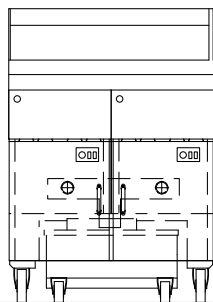
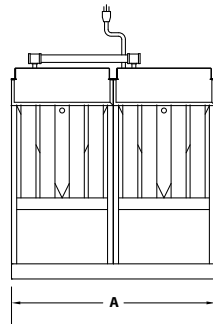

DEAN GAS LINE TABLE	
# OF FRYERS	GAS LINE WITH FILTER
2-4	(1) 1"
5	(2) 1"

DIMENSIONS

MODEL NUMBER	OIL CAPACITY	OVERALL SIZE (cm)			DRAIN HEIGHT (cm)	NO. OF TUBES	SHIPPING INFORMATION					
		A	B	HEIGHT			WEIGHT	CLASS	CU. FT.	DIMENSIONS (cm)		
SCFD250G	50 lb. (25 liter) per frypot	31" (79)	31-1/4"* (79.4)	45"* (114.3)	19-3/4" (50)	4	397 (180)	85	68	W 53" (134.6)	D 42" (106.6)	H 53" (134.6)
SCFD350G		610 (277)					88			66" (167.6)	42" (106.7)	55" (135.7)
SCFD450G		910 (413)					111			83" (210.8)	42" (106.7)	55" (135.7)
SCFD550G		1,311 (595)					SCFD550G & SCF650G Ship in 2 crates.					
SCFD260G	75 lb. (37 liter)	40" (102)	36-1/2"* (92.7)	45"* (114.3)	19-3/4" (50)	5	417 (189)	77.5	68	53" (134.6)	42" (106.6)	53" (134.6)
SCFD360G		815 (370)					88		66" (167.6)	42" (106.7)	55" (135.7)	
SCFH460G		1,295 (587)					111		83" (210.8)	42" (106.7)	55" (135.7)	

*Without basket lifts.

8700 Line Avenue
Shreveport, LA 71106
USA

Tel: 318-865-1711
Tel: 1-800-221-4583
Fax: 318-868-5987
E-mail: info@frymaster.com

www.frymaster.com
Bulletin No. 830-0043
Revised 5/20/16



Model # _____
CSI Section 11400



NOTES

- 1-1/2" (3.8 cm) kitchen main manifold gas supply line required. Gas inlet size (I.D.) should be no smaller than that provided for connection to the fryers. See service manual and/or plumbing codes for proper pipe sizing. Recommended minimum store manifold pressure to be 6" W.C. for natural gas and 11" W.C. for LP gas. Check plumbing codes for proper supply line sizing to attain burner manifold pressure of 3.0" W.C. natural or 8.25" W.C. LP.
- POWER CORDS: 2 battery units, 1 power cord supplied
3 to 4 battery units, 2 power cords supplied
5 battery units, 3 power cords supplied
- Please specify: Natural or LP gas; altitude if between 2,000 - 6,000 feet (610 - 1,829 Meters).

• DO NOT CURB MOUNT

CLEARANCE INFORMATION

- A minimum of 24" (61.0 cm) should be provided at the front of the unit for servicing and proper operation, and 6" (15.2 cm) between the sides and rear of the fryer to any combustible material.

HOW TO SPECIFY EXAMPLES:

The following description will assist with ordering the features desired for this equipment:

SCFD350G	Three 50-lb. tube-type gas fryers with Thermatron controllers, RTD 1° compensating temperature probe and 1-1/4" full port drain valve, built-in filtration, casters.
SCFD360G	Three 75-lb. tube-type gas fryers with Thermatron controllers, RTD 1° compensating temperature probe and 1-1/2" full port drain valve, built-in filtration, casters.

8700 Line Avenue
Shreveport, LA 71106
USA

Tel: 318-865-1711
Tel: 1-800-221-4583
Fax: 318-868-5987
E-mail: info@frymaster.com

www.frymaster.com
Bulletin No. 830-0043
Revised 5/20/16

