

# WORKTOP FREEZER (0°F)

## Model: SWF32NBS-D

Natural Refrigerant R-290 Model

### 32" Worktop Freezer with Drawers and 5 1/2" Backsplash

Stainless steel front, top and end panels, aluminum back and interior.



#### Options and Accessories

(upcharge and lead times may apply)

Stainless steel interior	Adjustable legs
Stainless steel back	Drawers locks
Overshelves (single or double)	Special electrical requirements (consult factory)

Consult factory for other model configurations, options and accessories.

Project Name:

Model Specified:

Location:

Item No:

Quantity:

AIA #:

SIS #:

#### Standard Model Features

##### REFRIGERATION SYSTEM

Performance-rated refrigeration system

Natural, environmentally-safe, high-efficiency R-290 refrigerant<sup>1</sup>

Automatic, energy saving, non-electric condensate evaporator

Non-corrosive, plasticized fin evaporator coil

Easily serviceable, back mounted compressor

##### CABINET ARCHITECTURE

2" non-CFC polyurethane foam insulation

Smooth, polished chrome drawer handles

Stainless steel roll-out drawers

Magnetic snap-in drawer gaskets

Completely enclosed, vented and removable case back

5" casters

##### MODEL FEATURES

Electronic controller w/digital display & hi-low alarm

Automatic electric defrost

<sup>1</sup> R-290 refrigerant meets all federal and state regulatory requirements.

**Continental**<sup>®</sup>  
Refrigerator

Toll-Free: 800-523-7138  
Phone: 215-244-1400  
Fax: 215-244-9579

539 Dunksferry Road  
Bensalem, PA 19020  
[www.continentalrefrigerator.com](http://www.continentalrefrigerator.com)

APPROVAL:

## Model Specifications

### DIMENSIONAL DATA

Net Capacity (cu. ft.)	9.0 (253 cu l)
Width, Overall (in.)	32 (813 mm)
Depth, Overall (in.) (incl. handles & bumpers)	32 3/16 (818 mm)
Height, Overall (in.) (incl. 5" casters)	40 3/4 (1035 mm)
No. of Drawers (two tier)	2

### REFRIGERANT DATA

Condensing Unit Size (H.P.)	1/3
Capacity (BTU/Hr)*	1800

### ELECTRICAL DATA

Voltage (int'l)	115/60/1 (220/50/1)
Total Amps (int'l)	5.6 (3.3)
Defrost Amps (int'l)	4.8 (2.4)
10 ft. Cord/Plug [attached] (int'l)	Yes (No)

### SHIPPING DATA

Weight (lbs.)	221 (100 kg)
Height - Crated (in.)	43 1/4 (1099 mm)
Width - Crated (in.)	40 (1016 mm)
Depth - Crated (in.)	37 1/4 (946 mm)

### DRAWER PAN CONFIGURATIONS

**Two Tier:** (1) 12 x 20 x 6 pan per drawer  
or (1) 1/2 size x 6 & (2) 1/3 x 6 pans per drawer

\* Rating @ -15°F evaporator, 90°F ambient

Figures in parentheses reflect metric equivalents rounded to the nearest whole unit.



Equipped with one NEMA-5-15P Plug  
(varies by country)

## Model Plan Views

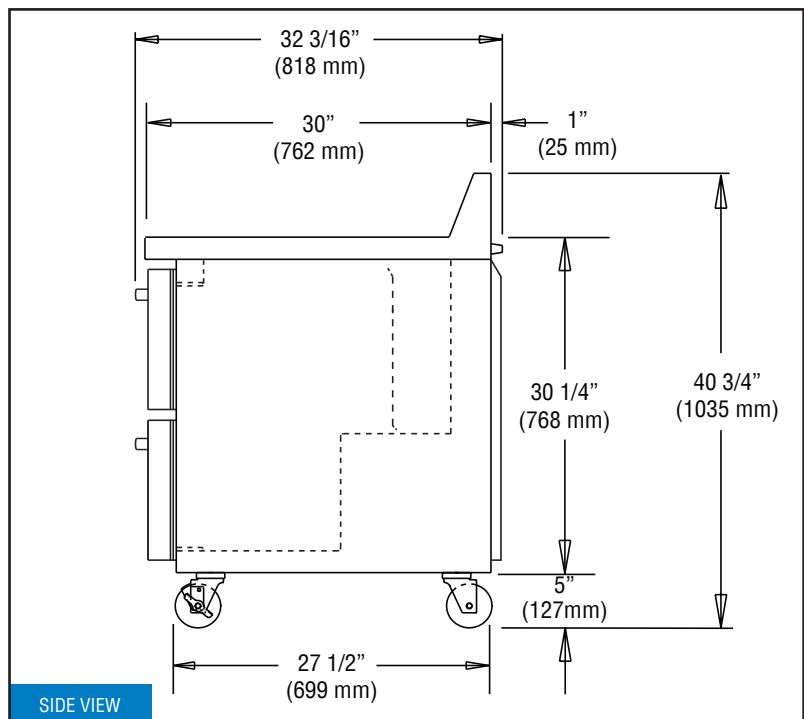
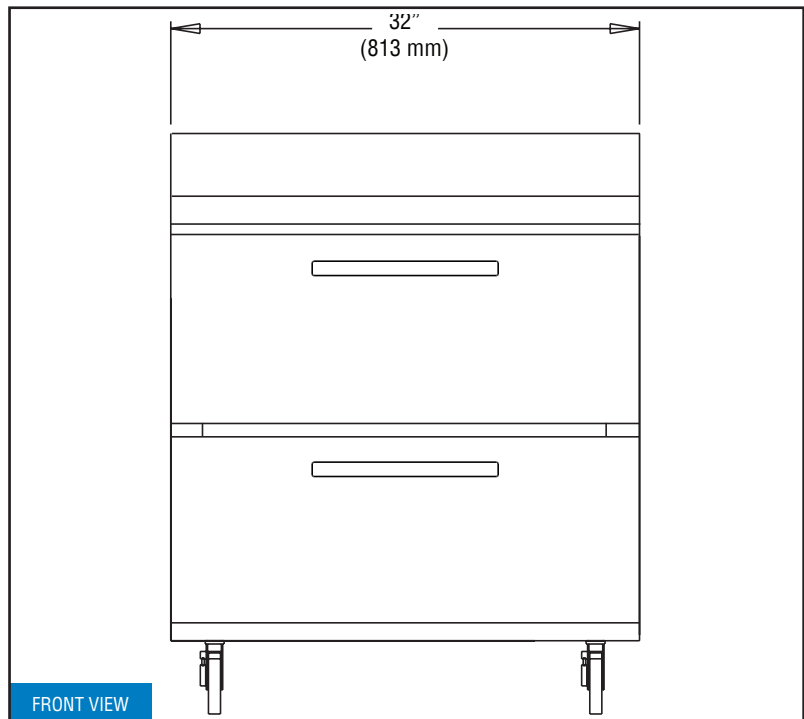

**IMPORTANT NOTE:** If the cabinet is located directly against a wall, a minimum clearance of 3" is required on sides, front and rear.

**Continental**  
Refrigerator

Toll-Free: 800-523-7138  
Phone: 215-244-1400  
Fax: 215-244-9579

539 Dunkserry Road  
Bensalem, PA 19020  
[www.continentalrefrigerator.com](http://www.continentalrefrigerator.com)

Due to our continued efforts in developing innovative products, specifications subject to change without notice.



MADE IN THE U.S.A.

© Copyright 2020. Continental Refrigerator.  
A Division of National Refrigeration & Air Conditioning Products, Inc.

SWF32NBS-D (8/12/20)