

WORKTOP REFRIGERATOR

Model: SW60NBS-FB-D

Natural Refrigerant R-290 Model

60" Worktop Refrigerator with Drawers and 5 1/2" Backsplash - Front Breathing

Stainless steel front, top and end panels, aluminum back and interior.



Options and Accessories

(upcharge and lead times may apply)

Stainless steel interior	Expansion valve system
Stainless steel back	Drawers locks
Overshelves (single or double)	Special electrical requirements (consult factory)

Consult factory for other model configurations, options and accessories.

Project Name:

Model Specified:

Location:

Item No:

Quantity:

AIA #:

SIS #:

Standard Model Features

REFRIGERATION SYSTEM

Performance-rated refrigeration system

Natural, environmentally-safe, high-efficiency R-290 refrigerant¹

Automatic, hot gas condensate evaporator

Non-corrosive, plasticized fin evaporator coil

Easily serviceable, back mounted compressor

CABINET ARCHITECTURE

2" non-CFC polyurethane foam insulation

Smooth, polished chrome drawer handles

Stainless steel roll-out drawers

Magnetic snap-in drawer gaskets

Completely enclosed, vented and removable case back

3 3/4" casters

MODEL FEATURES

Electronic controller w/digital display & hi-low alarm

¹ R-290 refrigerant meets all federal and state regulatory requirements.

Front breathers are a unique, field assembled, bottom mounted ventilation system designed to allow cabinets to be flush against a wall or built into a counter to conserve space.

Continental[®]
Refrigerator

Toll-Free: 800-523-7138
Phone: 215-244-1400
Fax: 215-244-9579

539 Dunksferry Road
Bensalem, PA 19020
www.continentalrefrigerator.com

APPROVAL:

Model Specifications

DIMENSIONAL DATA

Net Capacity (cu. ft.)	17.0 (481 cu l)
Width, Overall (in.)	60 (1524 mm)
Depth, Overall (in.) (incl. handles & bumpers)	32 3/16 (818 mm)
Height, Overall (in.) (incl. 3 3/4" casters)	39 1/2 (1003 mm)
No. of Drawers (two tier)	4

REFRIGERANT DATA

Condensing Unit Size (H.P.)	1/5
Capacity (BTU/Hr)*	1625

ELECTRICAL DATA

Voltage (int'l)	115/60/1 (220/50/1)
Total Amps (int'l)	2.46 (1.85)
10 ft. Cord/Plug [attached] (int'l)	Yes (No)

SHIPPING DATA

Weight (lbs.)	297 (135 kg)
Height - Crated (in.)	47 1/2 (1207 mm)
Width - Crated (in.)	68 (1727 mm)
Depth - Crated (in.)	37 1/4 (946 mm)

DRAWER PAN CONFIGURATIONS

Two Tier: (1) 12 x 20 x 6 pan per drawer

* Rating @ +25°F evaporator, 90°F ambient

Figures in parentheses reflect metric equivalents rounded to the nearest whole unit.



Equipped with one NEMA-5-15P Plug
(varies by country)

Model Plan Views

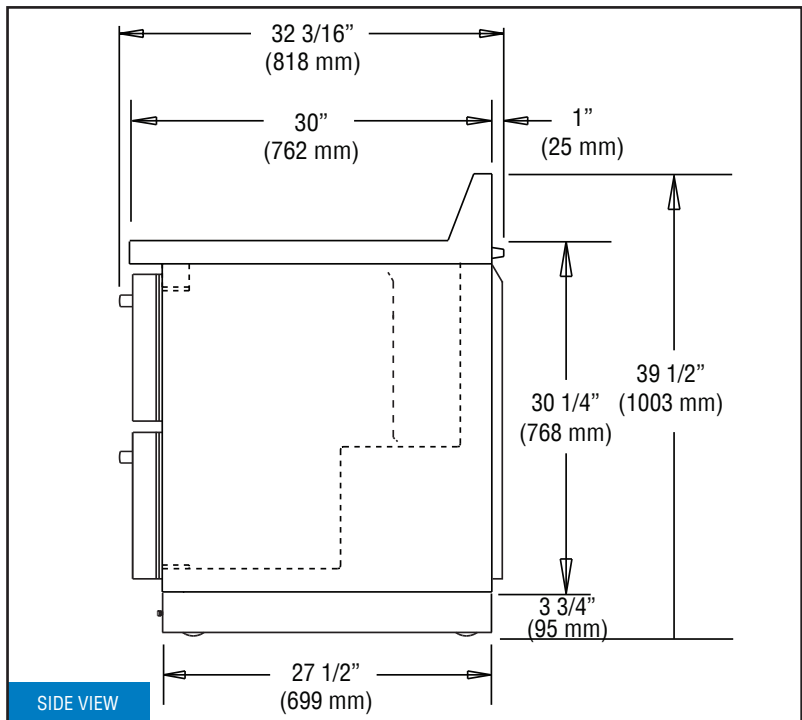
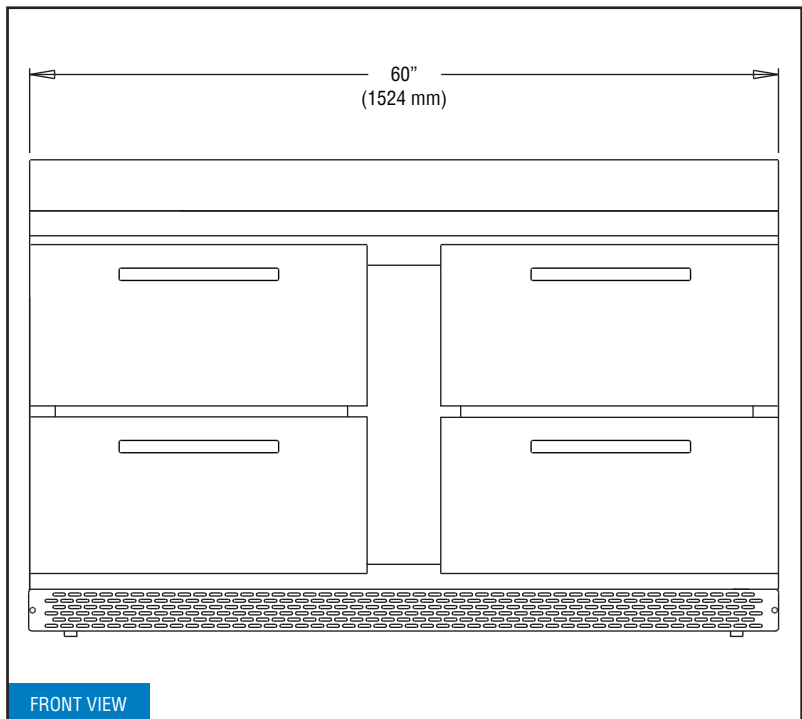

NOTE: For proper operation, the area under and in front of the cabinet **must** not be obstructed in any way.

Continental
Refrigerator

Toll-Free: 800-523-7138
Phone: 215-244-1400
Fax: 215-244-9579

539 Dunkserry Road
Bensalem, PA 19020
www.continentalrefrigerator.com

Due to our continued efforts in developing innovative products, specifications subject to change without notice.



MADE IN THE U.S.A.

© Copyright 2020. Continental Refrigerator.
A Division of National Refrigeration & Air Conditioning Products, Inc.