

# PIZZA PREPARATION TABLE

## Model: PA60N

Natural Refrigerant R-290 Model

### 60" Pizza Preparation Refrigerator with Solid Doors

Heavy gauge #300 series stainless steel top, stainless steel front and end panels, aluminum interior.



#### Options and Accessories

(upcharge and lead times may apply)

Stainless steel interior	Pan slides (larger section only)
Stainless steel back	Wire rod garnish rack
Overshelves (single or double)	Vision panel lid
Add'l epoxy-coated steel shelves	Door locks
Stainless steel shelves	Adjustable legs
Condensing unit on left (standard on right)	Front breathing
Drawer in lieu of half door above the condensing unit*	Special electrical requirements ( <i>consult factory</i> )

\*Drawer section above condensing unit holds (1) 12 x 20 x 6 pan  
Consult factory for other model configurations, options and accessories.

**Continental**<sup>®</sup>  
Refrigerator

Toll-Free: 800-523-7138  
Phone: 215-244-1400  
Fax: 215-244-9579

539 Dunksferry Road  
Bensalem, PA 19020  
[www.continentalrefrigerator.com](http://www.continentalrefrigerator.com)

Project Name:

Model Specified:

Location:

Item No:

Quantity:

AIA #:

SIS #:

#### Standard Model Features

##### REFRIGERATION SYSTEM

Performance-rated refrigeration system

Natural, environmentally-safe, high-efficiency R-290 refrigerant<sup>1</sup>

Unique forced air design utilizes fans (approx. every 12") across the entire back of unit for even distribution of cold

Automatic, hot gas condensate evaporator

Non-corrosive, plasticized fin evaporator coil

Easily serviceable, slide-out condensing unit

Expansion valve system

##### CABINET ARCHITECTURE

2" non-CFC polyurethane foam insulation

Smooth, polished chrome door handles

Spring loaded, self closing doors

Magnetic snap-in door gaskets

Heavy-duty, epoxy-coated steel shelves

19" deep, full length nylon cutting board

Insulated lids (with heavy-duty hinge pins)

(7) pan top divider bars\*

5" casters

\* Pans supplied by others

##### MODEL FEATURES

Reversing condenser fan<sup>2</sup>

Knob-type electronic controller mounted in control box

Ergonomically-friendly raised angle rail

Electronic control, off-cycle defrost

Refrigerated section w/door above the condensing unit

Field rehingeable doors

<sup>1</sup> R-290 refrigerant meets all federal and state regulatory requirements.  
<sup>2</sup> Fan runs in reverse for short period on startup to blow away any debris.

**NOTE:** Models come standard with a door above the condensing unit, a smaller width door (left section) and larger width door (center section). The option of having the doors located in the opposite sections **MUST** be indicated at the time of ordering. A drawer above the condensing unit is an option.

APPROVAL:

## Model Specifications

### DIMENSIONAL DATA

Net Capacity (cu. ft.)	19 (538 cu l)
Width, Overall (in.)	60 (1524 mm)
Depth, Overall (in.) (incl. cutting board & bumpers)	38 1/2 (972 mm)
Height, Overall (in.) (incl. 5" casters)	39 (989 mm)
Depth, Cutting Board (in.)	19 (483 mm)
Shelf Area (sq. ft.)	7.1 (.7 sq m)
No. of Shelves	2
No. of Full Doors	2
No. of Half Doors	1
Interior Depth (in.)	27 3/8 (695 mm)
Interior Height (in.)	26 (660 mm)
Interior Height (in.) (above condenser)	12 1/2 (318 mm)
Interior Width (in.)	56 (1422 mm)

### PAN TOP

Divider Bars (supplied with model)	(7) CM1-0111
Pan Capacity (pans supplied by others)	(8) 1/3

### REFRIGERANT DATA

Condensing Unit Size (H.P.)	1/3+
Capacity (BTU/Hr)*	3100

\* Rating @ +25°F evaporator, 90°F ambient

### ELECTRICAL DATA

Voltage (int'l)	115/60/1 (220/50/1)
Total Amps (int'l)	7.4 (5.4)
10 ft. Cord/Plug [attached] (int'l)	Yes (No)

### SHIPPING DATA

Weight (lbs.)	451 (205 kg)
Height - Crated (in.)	43 3/4 (1111 mm)
Width - Crated (in.)	62 (1575 mm)
Depth - Crated (in.)	47 (1194 mm)

Figures in parentheses reflect metric equivalents rounded to the nearest whole unit.



Equipped with one NEMA-5-15P Plug  
(varies by country)

**Continental**  
Refrigerator

Toll-Free: 800-523-7138  
Phone: 215-244-1400  
Fax: 215-244-9579

539 Dunkserry Road  
Bensalem, PA 19020  
[www.continentalrefrigerator.com](http://www.continentalrefrigerator.com)

Due to our continued efforts in developing innovative products, specifications subject to change without notice.



MADE IN THE U.S.A.

© Copyright 2020. Continental Refrigerator.  
A Division of National Refrigeration & Air Conditioning Products, Inc.

## Model Plan Views

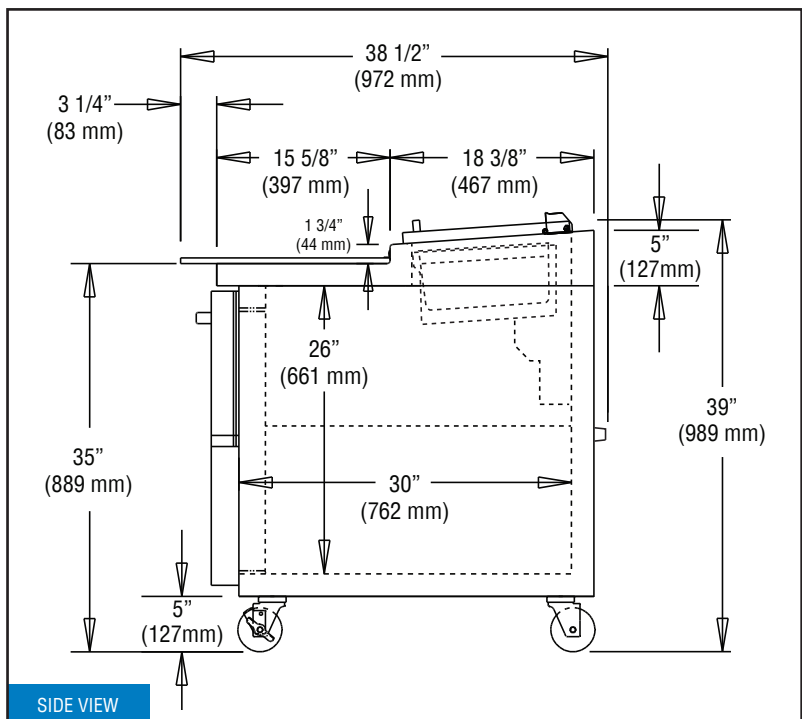
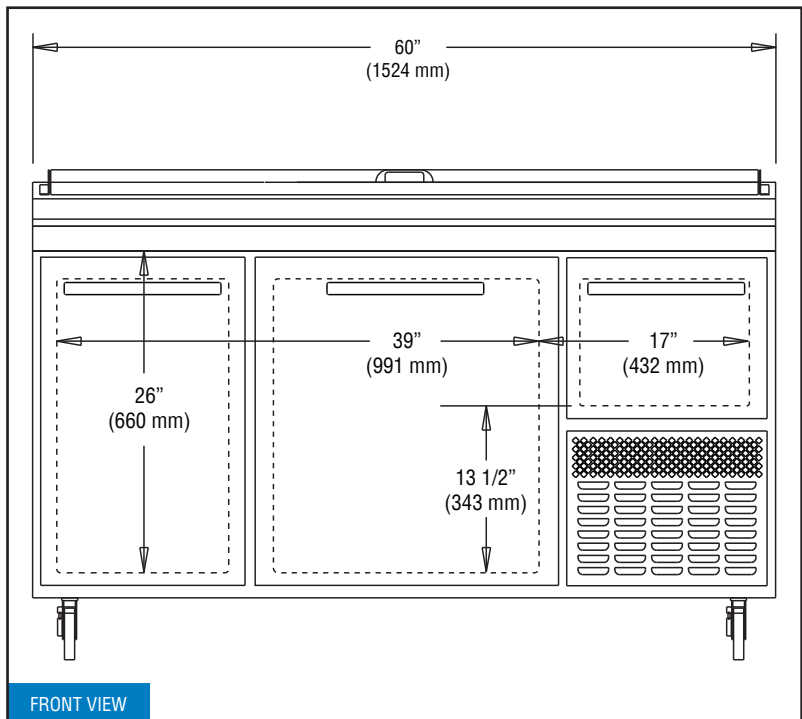

**IMPORTANT NOTE:** If the cabinet is located directly against a wall, a minimum clearance of 3" is required on sides, front and rear.