

PIZZA PREPARATION TABLE

Model: CPA118

118" Pizza Preparation Refrigerator with Solid Doors

Heavy gauge #300 series stainless steel top, stainless steel front and end panels, aluminum interior.



Options and Accessories

(upcharge and lead times may apply)

Stainless steel interior	Wire rod garnish rack
Stainless steel back	Vision panel lids
Add'l epoxy-coated steel shelves	Door locks
Stainless steel shelves	Adjustable legs
Condensing unit on left (standard on right)	Front breathing
Drawer in lieu of half door above the condensing unit*	Special electrical requirements (<i>consult factory</i>)
Pan slides	

*Drawer section above condensing unit holds (1) 12 x 20 x 6 pan
Consult factory for other model configurations, options and accessories.

Continental[®]
Refrigerator

Toll-Free: 800-523-7138
Phone: 215-244-1400
Fax: 215-244-9579

539 Dunksferry Road
Bensalem, PA 19020
www.continentalrefrigerator.com

Project Name:

Model Specified:

Location:

Item No:

Quantity:

AIA #:

SIS #:

Standard Model Features

REFRIGERATION SYSTEM

- Performance-rated refrigeration system
- Environmentally-safe R-450A refrigerant
- Unique forced air design utilizes fans (approx. every 12") across the entire back of unit for even distribution of cold
- Automatic, electric condensate evaporator
- Non-corrosive, plasticized fin evaporator coil
- Easily serviceable, slide-out condensing unit
- Expansion valve system

CABINET ARCHITECTURE

- 2" non-CFC polyurethane foam insulation
- Smooth, polished chrome door handles
- Spring loaded, self closing doors
- Magnetic snap-in door gaskets
- Heavy-duty, epoxy-coated steel shelves
- 19" deep, full length nylon cutting board
- Insulated lids (with heavy-duty hinge pins)
- (14) pan top divider bars*
- 5" casters

* Pans supplied by others

MODEL FEATURES

- Reversing condenser fan¹
- Knob-type electronic controller mounted in control box
- Ergonomically-friendly raised angle rail
- Electronic control, off-cycle defrost
- Refrigerated section w/door above the condensing unit
- Field rehingeable doors

¹ Fan runs in reverse for short period on startup to blow away any debris.

NOTE: Models come standard with a door above the condensing unit. A drawer above the condensing unit is an option.

APPROVAL:

Model Specifications

DIMENSIONAL DATA

Net Capacity (cu. ft.)	44 (1246 cu l)
Width, Overall (in.)	118 (2997 mm)
Depth, Overall (in.) (incl. cutting board & bumpers)	36 7/8 (937 mm)
Height, Overall (in.) (incl. 5" casters)	39 7/16 (1002 mm)
Depth, Cutting Board (in.)	19 (483 mm)
Shelf Area (sq. ft.)	18.4 (1.7 sq m)
No. of Shelves	4
No. of Full Doors	4
No. of Half Doors	1
Interior Depth (in.)	27 3/8 (695 mm)
Interior Height (in.)	26 (660 mm)
Interior Height (in.) (above condenser)	12 1/2 (318 mm)
Interior Width (in.)	114 (2896 mm)

PAN TOP

Divider Bars (supplied with model)	(14) CM1-0111
Pan Capacity (pans supplied by others)	(16) 1/3

REFRIGERANT DATA

Condensing Unit Size (H.P.)	3/4
Capacity (BTU/Hr)*	5600

* Rating @ +25°F evaporator, 90°F ambient

ELECTRICAL DATA

Voltage (int'l)	115/60/1 (220/50/1)
Total Amps (int'l)	16.6 (9.1)
10 ft. Cord/Plug [attached] (int'l)	Yes (No)

SHIPPING DATA

Weight (lbs.)	882 (400 kg)
Height - Crated (in.)	43 3/4 (1111 mm)
Width - Crated (in.)	120 (3048 mm)
Depth - Crated (in.)	47 (1194 mm)

Figures in parentheses reflect metric equivalents rounded to the nearest whole unit.



Equipped with one NEMA-5-20P Plug
(varies by country)

Model Plan Views

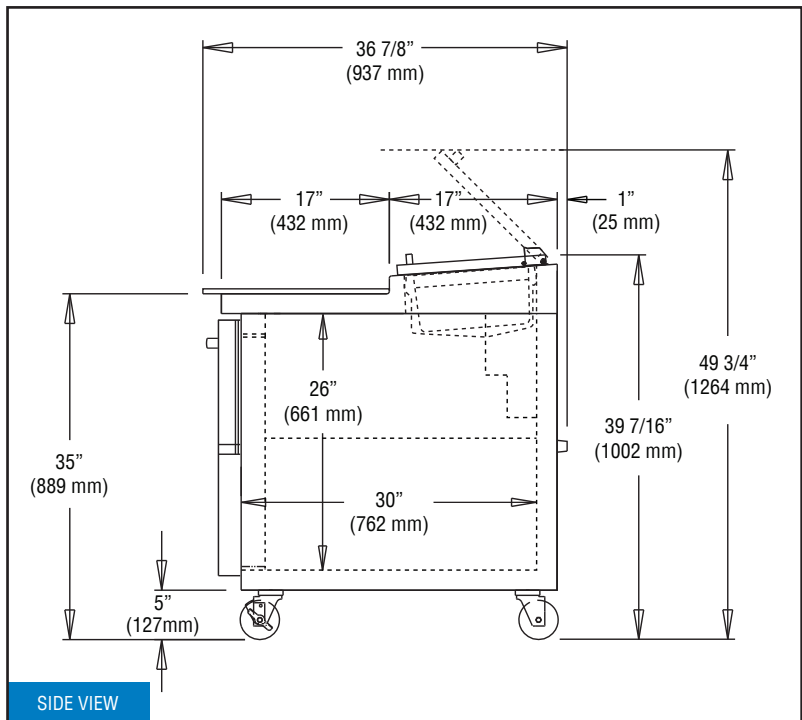
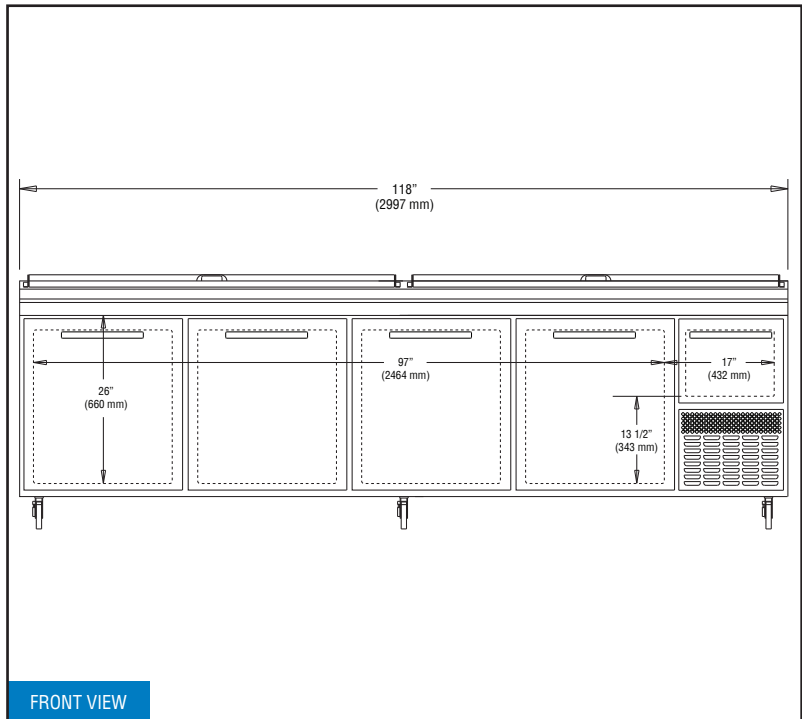

IMPORTANT NOTE: If the cabinet is located directly against a wall, a minimum clearance of 3" is required on sides, front and rear.

Continental
Refrigerator

Toll-Free: 800-523-7138
Phone: 215-244-1400
Fax: 215-244-9579

539 Dunksferry Road
Bensalem, PA 19020
www.continentalrefrigerator.com

Due to our continued efforts in developing innovative products, specifications subject to change without notice.



MADE IN THE U.S.A.

© Copyright 2020. Continental Refrigerator.
A Division of National Refrigeration & Air Conditioning Products, Inc.