

DESIGNER LINE REFRIGERATOR/WARMER

Model: DL2RW

Designer Line

2-Section Dual Temp, Reach-In Refrigerator/Warmer

Refrigerator (left)/Warmer (right). Sections can be changed at time of order.

- DL2RW** - Stainless steel front, aluminum end panels and interior
- DL2RW-SA** - Stainless steel exterior, aluminum interior
- DL2RW-SS** - Stainless steel exterior and interior



Options and Accessories

(upcharge and lead times may apply)

| | |
|--------------------------------------|--|
| Stainless steel case back | Increased refrigeration systems |
| Chrome or stainless steel shelves | Special electrical req. (consult factory) |
| Rehinging of doors (consult factory) | Refrigerator Section Only |
| Expansion valve system | Add'l epoxy-coated steel shelves |
| Pan slide assemblies | Wine Rack |
| Casters | Correctional Facility Options |
| Custom laminates | <ul style="list-style-type: none"> • One way security screws |
| Half doors | <ul style="list-style-type: none"> • Locking hasp (lock not included) |
| Hinged glass doors | <ul style="list-style-type: none"> • Stainless steel mesh cover |
| Pass-Thru | <ul style="list-style-type: none"> • Coverless hinges |

Consult factory for other model configurations, options and accessories.

Continental
Refrigerator

Toll-Free: 800-523-7138
Phone: 215-244-1400
Fax: 215-244-9579

539 Dunksferry Road
Bensalem, PA 19020
www.continentalrefrigerator.com

Project Name:

Model Specified:

Location:

Item No:

Quantity:

AIA #:

SIS #:

Standard Model Features

REFRIGERATOR SECTION

Separate, self-contained, performance-rated "plug" refrigeration system

Environmentally-safe R-134a refrigerant

(3) heavy-duty, epoxy-coated steel shelves

WARMER SECTION

Separate, self-contained, performance-rated heating system

90°F to 180°F temperature range

Top mounted heating plenum "plug" w/circulating fan

Stainless steel strip heaters located in base of interior

(3) heavy duty, chrome-plated steel shelves

CABINET ARCHITECTURE

3" non-CFC polyurethane foam insulation

Smooth, polished chrome workflow door handles

Cam action, lift off hinges

Self-closing doors

Magnetic snap-in door gaskets

Cylinder lock in each door

Adjustable 6" stainless steel legs

MODEL FEATURES

Unique air flow distribution ducts

Automatic interior lighting

(2) electronic controllers w/digital display & hi-low alarm

Automatic, hot gas condensate evaporator

Refrigeration/heating system is readily accessible on top of cabinet, separate from the "food zone"

Cabinet upper side panels and refrigeration "plug" system can be removed and reinstalled on job site

APPROVAL:

Model Specifications

DIMENSIONAL DATA [R/W]

| | |
|---------------------------------------|----------------------|
| Net Capacity (cu. ft.) | 21/21 (595/595 cu l) |
| Width, Overall (in.) | 52 (1321 mm) |
| Depth, Overall (in.) (incl. handles) | 35 3/8 (899 mm) |
| Depth (in.) (less doors) | 32 (813 mm) |
| Depth (in.) (doors open 90°) | 55 1/2 (1410 mm) |
| Clear Door Width (in.) | 19 3/8 (492 mm) |
| Clear Door Height (in.) | 58 5/8 (1489 mm) |
| Height, Overall (in.) (incl. 6" legs) | 83 1/4 (2115 mm) |
| No. of Doors | 2 |
| No. of Shelves | 6 |
| Shelf Area (sq. ft.) | 40.8 (3.8 sq m) |
| Tray Slide Capacity (refrigerator) | 24 |
| Tray Slide Capacity (warmer) | 19 |

REFRIGERANT DATA

| | |
|-----------------------------|------|
| Condensing Unit Size (H.P.) | 1/4 |
| Capacity (BTU/Hr)* | 1940 |

ELECTRICAL DATA [R/W]

| | |
|-------------------------------|---------------------|
| Voltage [R] (int'l) | 115/60/1 (220/50/1) |
| Voltage [W] | 208-230/60/1 |
| Feed Wires (incl. ground) | 3/3 |
| Total Amps (int'l) | 5.5 (3.5)/7.2 (7.2) |
| Total Wattage @ 208-230 volts | 2250 |
| 10 ft. Cord/Plug (int'l) | Yes (No)/No |

SHIPPING DATA

| | |
|----------------------------|------------------|
| Height - Crated (in.) | 85 1/2 (2172 mm) |
| Width - Crated (in.) | 64 (1626 mm) |
| Depth - Crated (in.) | 42 (1067 mm) |
| Volume - Crated (cu. ft.) | 133 (3766 cu l) |
| Weight Std - Crated (lbs.) | 580 (263 kg) |
| Weight SS - Crated (lbs.) | 610 (277 kg) |

* Rating @ +25°F evaporator, 90°F ambient

Figures in parentheses reflect metric equivalents rounded to the nearest whole unit.

Refrigerator Section Only:

Equipped with one NEMA-5-15P Plug (varies by country)



Model Plan Views

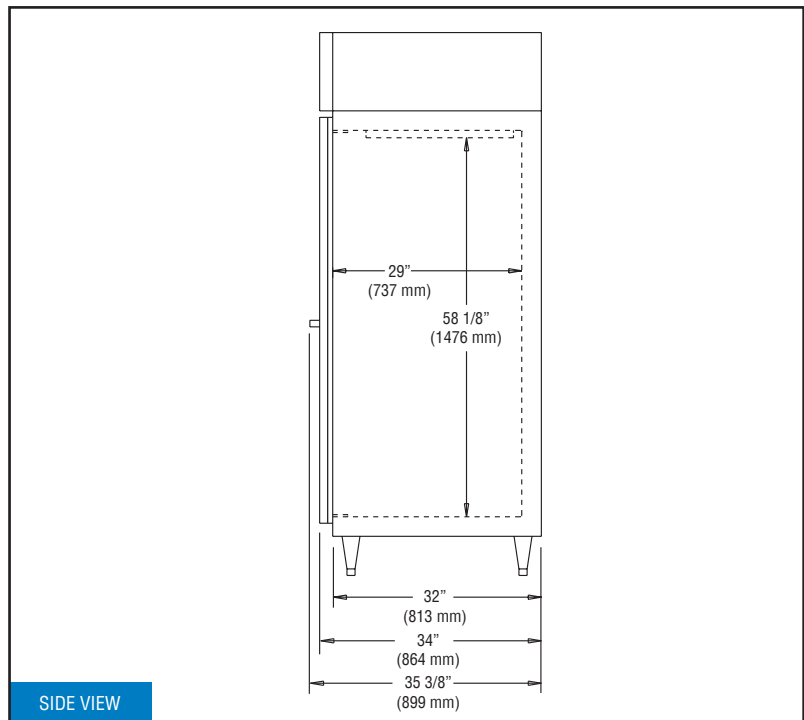
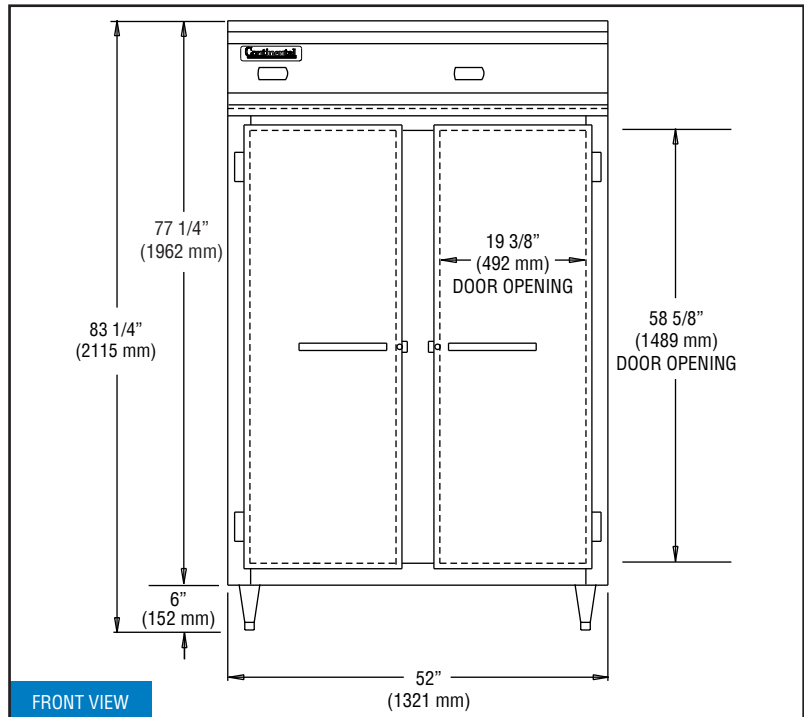

IMPORTANT NOTE: If the cabinet is located directly against a wall and/or under a low ceiling, a minimum clearance of 12" is required on top and 3" on sides and rear.

Continental
Refrigerator

Toll-Free: 800-523-7138
Phone: 215-244-1400
Fax: 215-244-9579

539 Dunkserry Road
Bensalem, PA 19020
www.continentalrefrigerator.com

Due to our continued efforts in developing innovative products, specifications subject to change without notice.



Intertek



MADE IN THE U.S.A.

© Copyright 2019, Continental Refrigerator.
A Division of National Refrigeration & Air Conditioning Products, Inc.