

REACH-IN FREEZER (0°F)

Model: 1FXNPT

Natural Refrigerant R-290 Model

1-Section Extra-Wide Pass-Thru Freezer

1FXNPT - Stainless steel front, aluminum end panels and interior
1FXNSAPT - Stainless steel exterior, aluminum interior
1FXNSSPT - Stainless steel exterior and interior
Designed to maintain NSF-7 temperatures in 100°F ambient.



Options and Accessories

(upcharge and lead times may apply)

Additional epoxy-coated steel shelves	Special electrical req. (consult factory)
Chrome or stainless steel shelves	Correctional Facility Options
Rehinging of doors (consult factory)	<ul style="list-style-type: none">• One way security screws
Adjustable legs	<ul style="list-style-type: none">• Locking hasp (lock not included)
Custom laminates	<ul style="list-style-type: none">• Stainless steel mesh cover
Hinged glass doors	<ul style="list-style-type: none">• Coverless hinges

Consult factory for other model configurations, options and accessories.

Continental[®]
Refrigerator

Toll-Free: 800-523-7138
Phone: 215-244-1400
Fax: 215-244-9579

539 Dunksferry Road
Bensalem, PA 19020
www.continentalrefrigerator.com

Project Name:

Model Specified:

Location:

Item No:

Quantity:

AIA #:

SIS #:

Standard Model Features

REFRIGERATION SYSTEM

Natural, environmentally-safe, high-efficiency R-290 refrigerant¹

Self contained, performance-rated refrigeration system

Automatic, electric condensate evaporator

CABINET ARCHITECTURE

3" non-CFC polyurethane foam insulation

Smooth, polished chrome workflow door handles

Cam action, lift off hinges

Self-closing doors

Magnetic snap-in Santoprene™ door gaskets

Cylinder lock in door

Heavy-duty, epoxy-coated steel shelves

5" casters

MODEL FEATURES

LED interior lighting

Expansion valve system

Digital thermometer

Automatic electric defrost

¹ R-290 refrigerant meets all federal and state regulatory requirements.

APPROVAL:

Model Specifications

DIMENSIONAL DATA

Net Capacity (cu. ft.)	30 (850 cu l)
Width, Overall (in.)	36 1/4 (921 mm)
Depth, Overall (in.) (incl. handles)	38 3/4 (984 mm)
Depth [less doors] (in.)	32 (813 mm)
Depth [doors open 90°] (in.)	100 (2540 mm)
Clear Door Width (in.)	29 5/8 (752 mm)
Clear Door Height (in.)	58 5/8 (1489 mm)
Height, Overall (in.) (incl. 5" casters)	82 1/4 (2096 mm)
No. of Doors	2
No. of Shelves	3
Shelf Area (sq. ft.)	24.4 (2.3 sq m)

REFRIGERANT DATA

Condensing Unit Size (H.P.)	1/2
Capacity (BTU/Hr)*	1840

ELECTRICAL DATA

Voltage (int'l)	115/60/1 (220/50/1)
Feed Wires (incl. ground)	3
Total Amps (int'l)	8.4 (4.9)
Defrost Amps	5.2 (2.6)
10 ft. Cord/Plug [attached] (int'l)	Yes (No)

SHIPPING DATA

Height - Crated (in.)	85 1/2 (2172 mm)
Width - Crated (in.)	42 (1067 mm)
Depth - Crated (in.)	42 (1067 mm)
Volume - Crated (cu. ft.)	87 (2464 cu l)
Weight Std - Crated (lbs.)	450 (204 kg)
Weight SS - Crated (lbs.)	510 (231 kg)
Weight Std - Uncrated (lbs.)	350 (159 kg)
Weight SS - Uncrated (lbs.)	410 (186 kg)

* Rating @ -15°F evaporator, 90°F ambient
 Figures in parentheses reflect metric equivalents rounded to the nearest whole unit.



Equipped with one NEMA-5-15P Plug
 (varies by country)

Model Plan Views

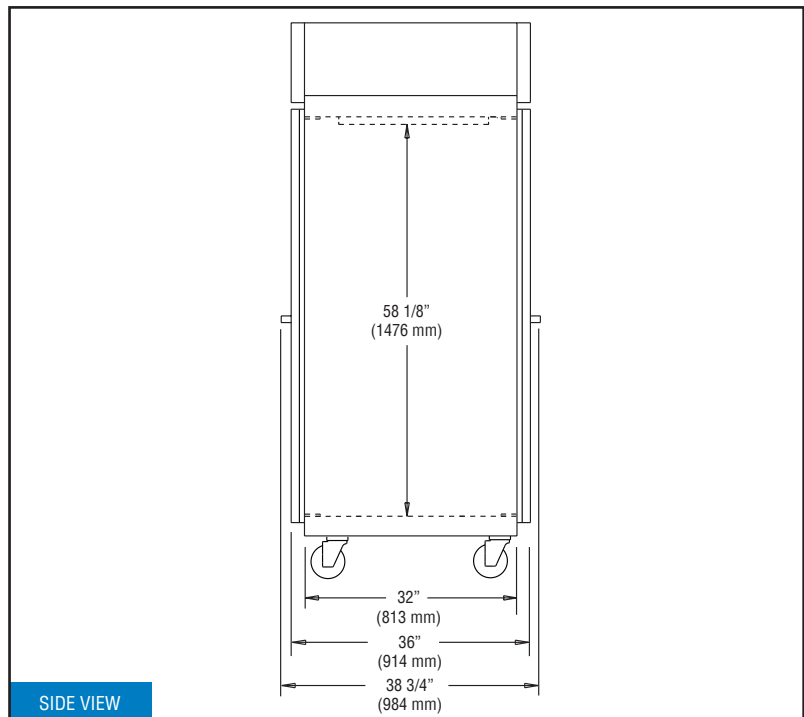
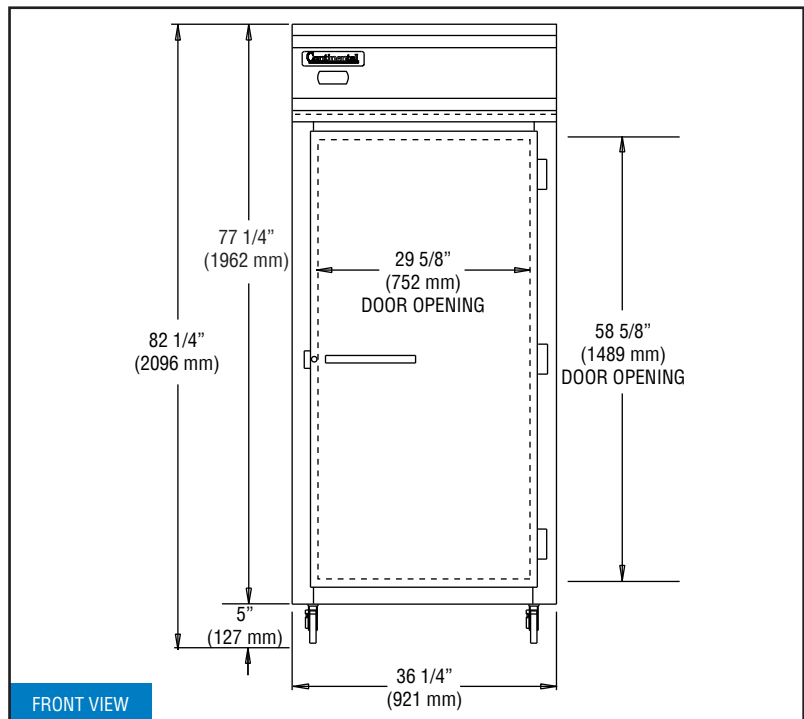

IMPORTANT NOTE: If the cabinet is located under a low ceiling, a **minimum clearance of 12"** is required on top and 3" on sides.

Continental
 Refrigerator

Toll-Free: 800-523-7138
 Phone: 215-244-1400
 Fax: 215-244-9579

539 Dunkserry Road
 Bensalem, PA 19020
www.continentalrefrigerator.com

Due to our continued efforts in developing innovative products, specifications subject to change without notice.



MADE IN THE U.S.A.

© Copyright 2020. Continental Refrigerator.
 A Division of National Refrigeration & Air Conditioning Products, Inc.