

BOTTLE COOLER (38°F - 41°F)

Model: CBC50

50" Bottle Cooler

Textured baked black enamel finish exterior with all stainless steel countertop and slide lids, heavy-duty galvanized interior.

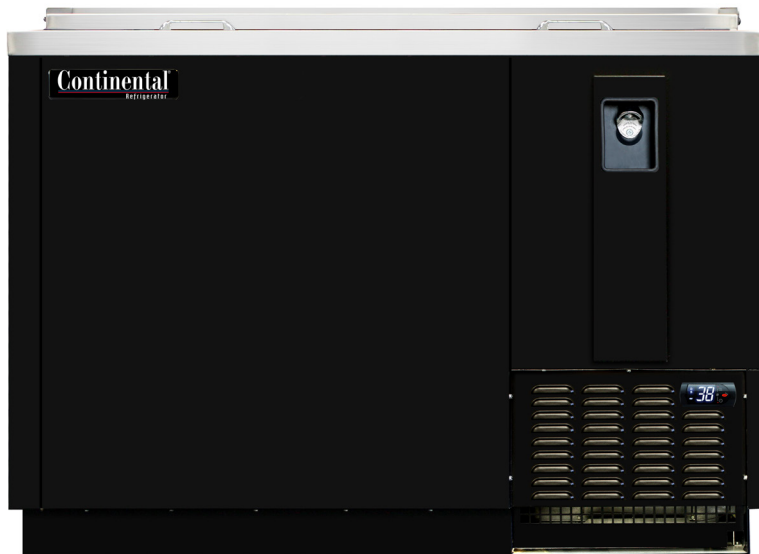

Options and Accessories

(upcharge and lead times may apply)

Stainless steel interior	Automatic, electric condensate evaporator
Add'l wire bin dividers	Casters
Lid locks	Adjustable legs
Expansion valve system	

Consult factory for other model configurations, options and accessories.

Project Name:

Model Specified:

Location:

Item No:

Quantity:

AIA #:

SIS #:

Standard Model Features

REFRIGERATION SYSTEM

Environmentally-safe R-134a refrigerant

Performance-rated refrigeration system

Automatic, energy-saving, non electric condensate evaporator

Full length, extra large coil

Easily accessible and serviceable slide-out condensing unit

CABINET ARCHITECTURE

High density, non-CFC polyurethane foamed-in-place insulation

Heavy-duty, epoxy-coated, adjustable steel wire storage bin dividers

Front, rear and side venting louvers

MODEL FEATURES

Heavy-duty cap opener w/extra capacity, removable cap catcher

Easily accessible, front-mounted cleanout drainage hose

Electronic controller w/digital display

Continental
Refrigerator

Toll-Free: 800-523-7138
Phone: 215-244-1400
Fax: 215-244-9579

539 Dunksferry Road
Bensalem, PA 19020
www.continentalrefrigerator.com

APPROVAL:

Model Specifications

DIMENSIONAL DATA

Net Capacity (cu. ft.)	15.1 (428 cu l)
12 oz. Bottle Capacity (# cases)	18
12 oz. Can Capacity (# cases)	27
Width, Overall (in.)	50 (1270 mm)
Depth, Overall (in.) (incl. bumpers & cap catcher)	29 1/8 (740 mm)
Height, Overall (in.)	33 1/2 (851 mm)
No. of Slide Lids	2
No. of Bin Dividers	3

REFRIGERANT DATA

Condensing Unit Size (H.P.)	1/3
Capacity (BTU/Hr)*	1910

ELECTRICAL DATA

Voltage (int'l)	115/60/1 (220/50/1)
Feed Wires (incl. ground)	3
Total Amps (int'l)	4.9 (3.8)
10 ft. Cord/Plug [attached] (int'l)	Yes (No)

SHIPPING DATA

Weight - (lbs.)	313 (142 kg)
Height - Crated (in.)	39 (991 mm)
Width - Crated (in.)	57 3/4 (1467 mm)
Depth - Crated (in.)	30 1/4 (768 mm)

* Rating @ +20°F evaporator, 90°F ambient

Figures in parentheses reflect metric equivalents rounded to the nearest whole unit.



Equipped with one NEMA-5-15P Plug
(varies by country)

Continental
Refrigerator

Toll-Free: 800-523-7138
Phone: 215-244-1400
Fax: 215-244-9579

539 Dunkserry Road
Bensalem, PA 19020
www.continentalrefrigerator.com

Due to our continued efforts in developing innovative products, specifications subject to change without notice.



Intertek



MADE IN THE U.S.A.

© Copyright 2019. Continental Refrigerator.
A Division of National Refrigeration & Air Conditioning Products, Inc.

Model Plan Views

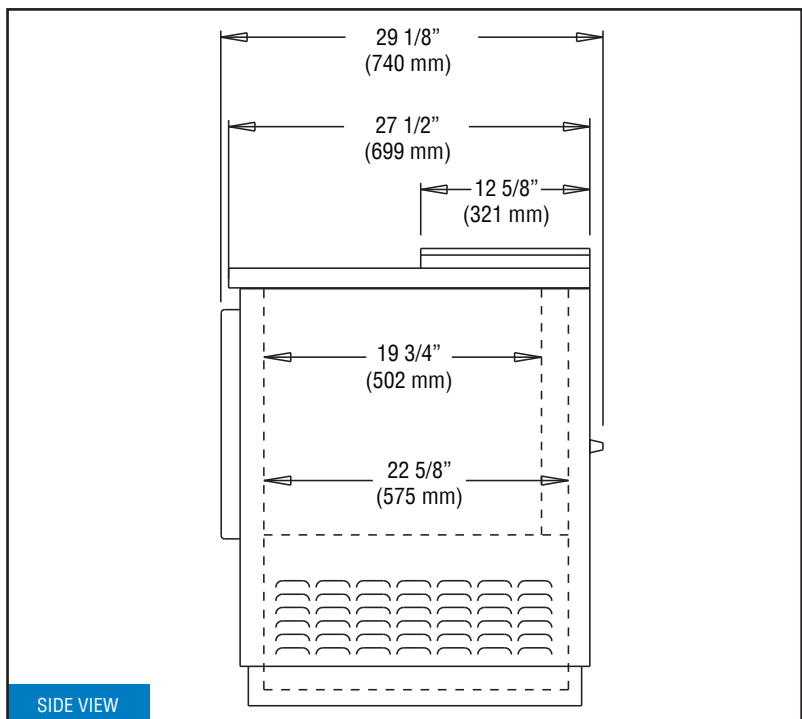
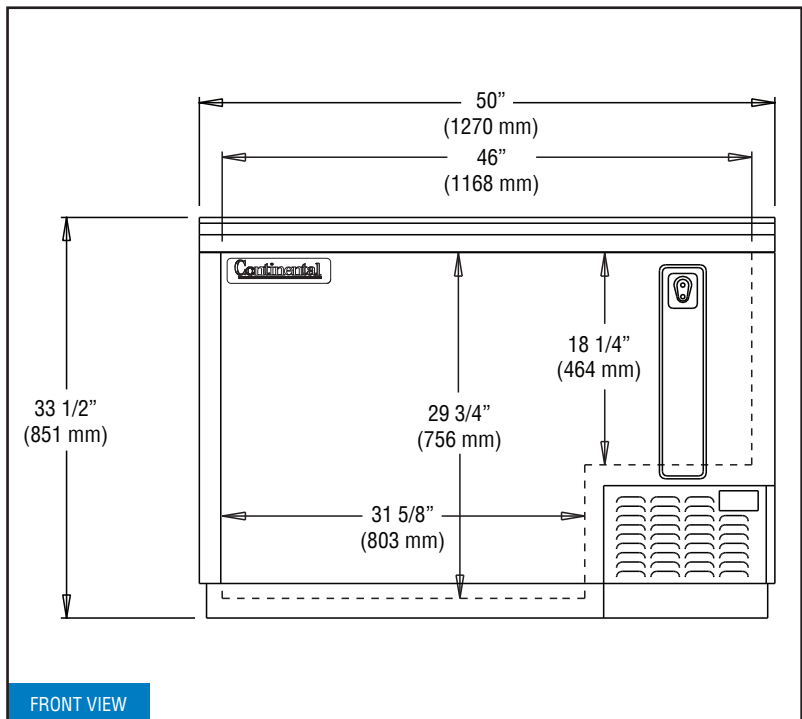

IMPORTANT NOTE: A minimum clearance of 3" is required on each side, front and rear of cabinet for optimum performance.