

DISPLAY REFRIGERATOR

Model: 2RNSGDHD

Natural Refrigerant R-290 Model

2-Section Display Reach-In Refrigerator with Half Sliding Glass Doors

2RNSGDHD - Stainless steel front, aluminum end panels and interior

2RNSASGDHD - Stainless steel exterior, aluminum interior

2RNSSGDHD - Stainless steel exterior and interior



Options and Accessories

(upcharge and lead times may apply)

Stainless steel case back	Pan slide assemblies
Add'l epoxy-coated steel shelves	Wine rack
Chrome or stainless steel shelves	Adjustable legs
Heavy-duty pilaster strips	Special electrical req. (consult factory)

Consult factory for other model configurations, options and accessories.

Continental[®]
Refrigerator

Toll-Free: 800-523-7138
Phone: 215-244-1400
Fax: 215-244-9579

539 Dunksferry Road
Bensalem, PA 19020
www.continentalrefrigerator.com

Project Name:

Model Specified:

Location:

Item No:

Quantity:

AIA #:

SIS #:

Standard Model Features

REFRIGERATION SYSTEM

Self contained, performance-rated refrigeration system

Natural, environmentally-safe, high-efficiency R-290 refrigerant¹

Automatic, electric condensate evaporator

Expansion valve system

CABINET ARCHITECTURE

3" non-CFC polyurethane foam insulation

Double-pane, tempered sliding glass doors

Self-closing doors

Snap-in door wipers

Door locks

Heavy-duty, epoxy-coated steel shelves

High efficiency Black PVC frames

5" casters

MODEL FEATURES

LED interior lighting

Electronic controller w/digital display & hi-low alarm

¹ R-290 refrigerant meets all federal and state regulatory requirements.

APPROVAL:

Model Specifications

DIMENSIONAL DATA

Net Capacity (cu. ft.)	48 (1359 cu l)
Width, Overall (in.)	52 (1321 mm)
Depth, Overall (in.) (incl. grill)	34 (mm)
Depth (in.) (less grill)	32 (813 mm)
Clear Door Width (in.)	17 3/4 (451 mm)
Clear Half Door Height (in.)	26 7/8 (699 mm)
Height, Overall (in.) (incl. 5" casters)	82 1/4 (2096 mm)
No. of Doors	4
No. of Shelves	8
Shelf Area (sq. ft.)	40.8 (3.8 sq m)
Tray Slide Capacity (per half section)	11

REFRIGERANT DATA

Condensing Unit Size (H.P.)	1/3+
Capacity (BTU/Hr)*	2560

ELECTRICAL DATA

Voltage (int'l)	115/60/1 (220/50/1)
Feed Wires (incl. ground)	3
Total Amps (int'l)	7.9 (5.1)
10 ft. Cord/Plug [attached] (int'l)	Yes (No)

SHIPPING DATA

Height - Crated (in.)	85 1/2 (2172 mm)
Width - Crated (in.)	64 (1626 mm)
Depth - Crated (in.)	42 (1067 mm)
Volume - Crated (cu. ft.)	133 (3766 cu l)
Weight Std - Crated (lbs.)	469 (213 kg)
Weight SS - Crated (lbs.)	610 (277 kg)

* Rating @ +25°F evaporator, 90°F ambient

Figures in parentheses reflect metric equivalents rounded to the nearest whole unit.



Equipped with one NEMA-5-15P Plug
(varies by country)

Continental
Refrigerator

Toll-Free: 800-523-7138
Phone: 215-244-1400
Fax: 215-244-9579

539 Dunkserry Road
Bensalem, PA 19020
www.continentalrefrigerator.com

Due to our continued efforts in developing innovative products, specifications subject to change without notice.



MADE IN THE U.S.A.

© Copyright 2020. Continental Refrigerator.
A Division of National Refrigeration & Air Conditioning Products, Inc.

Model Plan Views

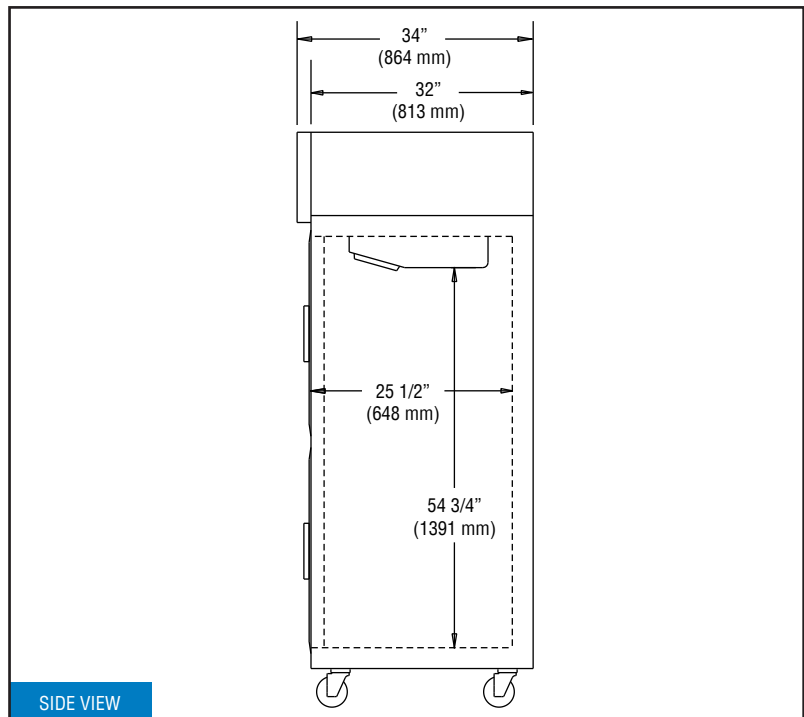
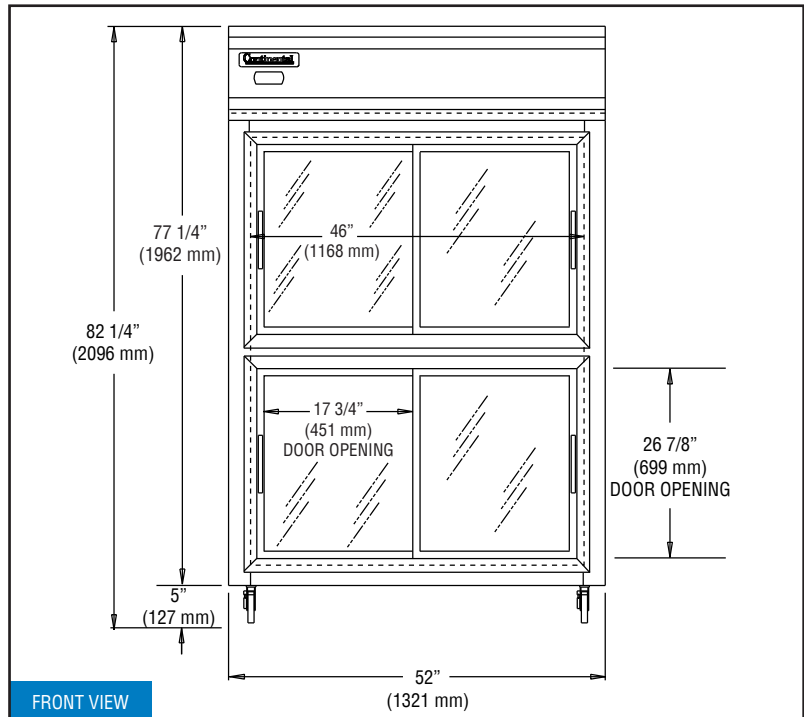

IMPORTANT NOTE: If the cabinet is located directly against a wall and/or under a low ceiling, a minimum clearance of 12" is required on top and 3" on sides and rear.