

MIXER KETTLES, GAS-FIRED VERTICAL AGITATOR TILTING, 2/3 STEAM JACKETED

Project _____
 Item _____
 Quantity _____
 FCSI Section 11400 _____
 Approved _____
 Date _____

Models

- MKGL-40-T • MKGL-80-T
- MKGL-60-T



Standard Features

- High Efficiency (65%) Forced Air Double Pass Heating System. 140M BTU on 40 gallons, 190M BTU on 60 and 80 gallons
- Automatic Ignition System and 50 psi Steam Jacket Rating
- Insulated Heat Exchanger
- Enclosed, Balanced 10 gauge Stainless Steel hydraulically operated mixer-bridge
- Steam Jacket permanently filled with treated distilled water
- Recessed, front-mounted Pressure/Vacuum Gauge
- Solid-State, precise temperature controls with less than 1° C temperature differences. LED indicator for Heat Cycle and Low Water Indicator, Power On/Off Switch
- Infinitely Variable Ratio Control between Scraper and Agitator. Agitator rotates from 0 to 8 times the speed of the Scraper. Infinitely Variable Scraper Speed Controls from 0 to 45 RPM
- 3-horsepower hydraulic powered Agitator, Scraper and Bridge Lift. Nylon Scraper Blades removable without tools
- 3" diameter Quick Opening Butterfly Valve
- Hot & Cold Water Faucet. (DPK)
- Tilt Mechanism of roller bearings and case hardened self-locking machined worm and segment gear
- Standard for natural gas operation, standard voltage is 120/208-240, 3 phase
- Level adjustable flanged feet, Gallon markings on Scraper Shaft
- Typical approvals include AGA, CSA, CE, NSF and ASME
- Safety Cover and Screen included on Mixer Bridge
- 316 Stainless Steel Interior
- Two piece cover with safety screen

Short Form Specifications

Cleveland Gas-Fired Tilting Vertical Mixer Kettle. MKGL-___T ___ gallons, 2/3 steam jacketed, 65% efficient forced air double pass heating system, 50 psi steam jacket rating, type 316 stainless steel interior, automatic ignition, solid-state splash-proof controls, 3" Diameter Butterfly Valve. 316 Stainless Steel Interior.

Options & Accessories

- 3" Air Operated Flush Piston Valve. (FPVA3) (for use with a food pump, replaces 3" butterfly valve) (requires air compressor)
- Water Meters (GMC1 or LMC1)
- Product Time / Temperature Controls & Indicator. (DTCI)
- Pan Carriers (PCK), Food Strainers. (FS)
- Kettle Accessory Kit (KAK) includes:
 - Clean-up Brush (CB)
 - 36" Kettle Paddle (KP)
 - 36" Kettle Whip (KW)
 - 36" Kettle Brush (KB)
 - Draw-off Brush (DB)
 - 24 oz. Ladle (KL)
- Tri-Basket Strainer Support Systems. (TBS)
- Temperature Chart Recorder (TCR)

KE004046-83

DIMENSIONS (ALL DIMENSIONS ARE IN INCHES):

MODEL NO.	A	B	C	D	E	F	G	H	I	J	K	L	M	N	O	P	Q	R	S (I.D.)	T	U	V
MKGL-40-T	48	25	63 3/4	70	40 1/2	48	13 1/2	13 1/2	8 3/8	24	23	25	22 1/2	13	21	34	69 3/4	53 3/4	26	55 1/4	15 1/4	14 1/4
MKGL-60-T	50 1/2	25 1/2	66 5/8	74	43 3/4	52	14 1/4	14	9 1/8	25	26	28	23 3/4	13 1/4	20 1/2	35 1/8	70	55	29 1/2	58 1/8	16 1/2	14 1/2
MKGL-80-T	54	26	70 3/8	77	44 3/4	54	15 3/4	14 1/2	10 5/8	27	28	30	25 1/4	11 3/4	21 5/8	35 3/4	71 1/2	55 1/2	33	61 7/8	17	13

SPECIFICATIONS:

MODEL	ELECTRICAL SUPPLY:				GAS SUPPLY: (PIPING 3/4 NPT)				APPROVALS				CLEARANCE:	SHIPPING WEIGHT	
	VOLTS	PH	AMPS	FREQ	TYPE	BTU RATING	WATER COLUMN	BTU PER CU. FT.	SUPPLY PRESSURE	AGA	CGA	CE MARK			NSF
MKGL-40-T	208/240	3	15	60	NAT	140,000	3.5	1000	4" TO 14" W.C.	*	*		*	RIGHT: 0 inches LEFT: 0 inches REAR: 0 inches	MKGL-40-T 850 LBS.
	208/240	3	15	60	LP	140,000	3.5	2500	4" TO 14" W.C.	*	*		*	ALLOW 6.00" SPACE MINIMUM FROM REAR AND SIDES WHEN LOCATED NEAR COMBUSTIBLE WALLS	
	480	3	8	60	NAT	140,000	3.5	1000	4" TO 14" W.C.				*		
MKGL-60-T	208/240	3	15	60	NAT	190,000	3.5	1000	4" TO 14" W.C.	*	*		*	MKGL-60-T 925 LBS.	
	208/240	3	15	60	LP	190,000	3.5	2500	4" TO 14" W.C.	*	*		*		
	480	3	8	60	NAT	190,000	3.5	1000	4" TO 14" W.C.				*		
MKGL-80-T	480	3	8	60	NAT	190,000	3.5	1000	4" TO 14" W.C.				*	MKGL-80-T 1000 LBS.	
	480	3	8	60	LP	190,000	3.5	2500	4" TO 14" W.C.		*	*	*		
NOTES:											4.00" CLEARANCE REQUIRED IF ADJOINING EQUIPMENT IS OVER 36" HIGH				
1. MANUFACTURER MUST BE NOTIFIED IF UNIT WILL BE OPERATING ABOVE 2,000 FOOT ALTITUDE.															
2. CONSULT FACTORY FOR MANUFACTURED GAS.															
3. ALL VERTICAL DIMENSIONS SHOWN ARE MINIMUM. FEET ARE ADJUSTABLE TO 1 INCH MAXIMUM.															

1. MANUFACTURER MUST BE NOTIFIED IF UNIT WILL BE OPERATING ABOVE 2,000 FOOT ALTITUDE.
2. CONSULT FACTORY FOR MANUFACTURED GAS.
3. ALL VERTICAL DIMENSIONS SHOWN ARE MINIMUM. FEET ARE ADJUSTABLE TO 1 INCH MAXIMUM.

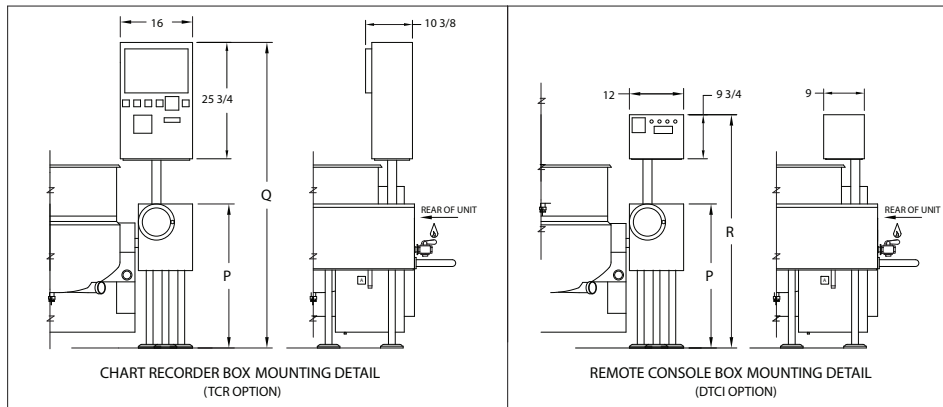
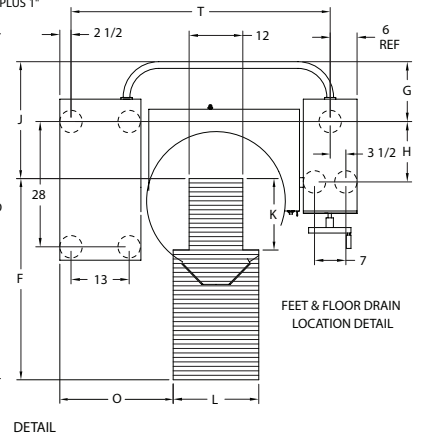
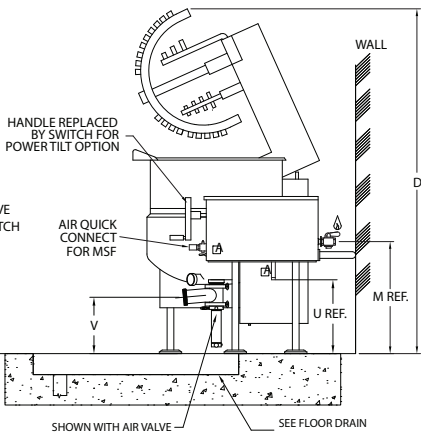
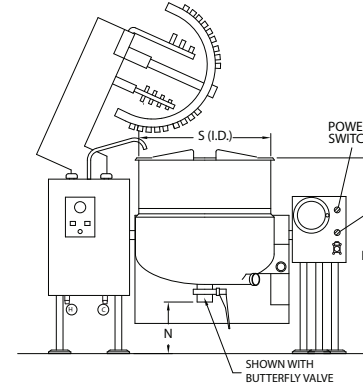
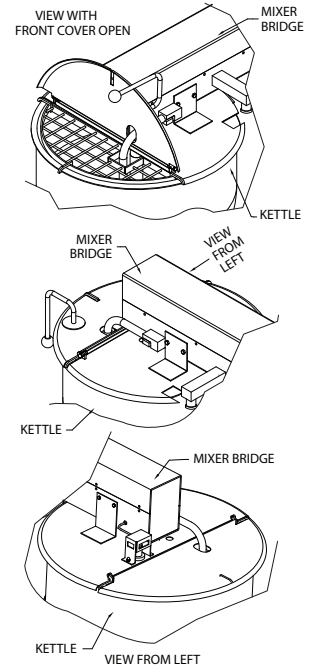
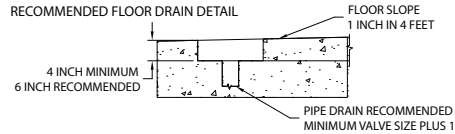
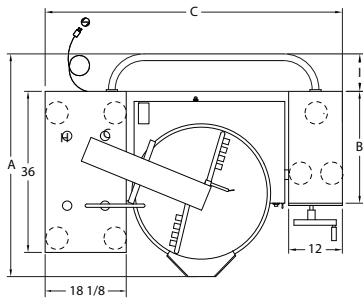
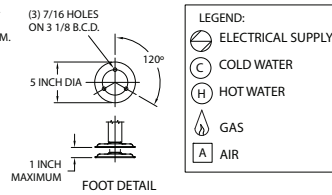

NOTES:

Cleveland Range reserves right of design improvement or modification, as warranted.
 Many regional, state and local codes exist and it is the responsibility of the owner and installer to comply with the codes.
 Installation of backflow preventers, vacuum breakers and other specific code requirements is the responsibility of the owner and installer.
 Cleveland Range equipment is built to comply with applicable standards for manufacturers. Included among those approval agencies are U.L., A.G.A., NSF, ASME/N.Bd., CSA, CGA, ETL and others.

(NOT TO SCALE)

Mixer Kettles