



BEVERAGE-AIR

Project: _____	AIA#
Item: _____	
Location: _____	SIS#
Approved: _____	

FOOD PREPARATION SERIES

DPD72HC Deli/Pizza Prep Table with Four Drawers Hydrocarbon Series

MODEL:**DPD72HC-4**

DPD72HC FOOD PREPARATION : DELI/PIZZA PREP SERIES

3 Year Parts/Labor Warranty
Additional 4 Year Compressor Warranty

CABINET CONSTRUCTION

- Stainless steel front, sides, top, drawers and grille (galvanized back & bottom)
- Interior liner is made of corrosion resistant aluminum
- Aluminum top interior liner prevents spill from falling into cabinet
- Stainless steel top
- Removable hoods and insulated lid assemblies are made of matching stainless steel
- Magnetic gaskets provide positive seal on drawers
- 3" Casters, 2 with brakes standard
- 19" Wide reversible cutting board is removable for easy cleaning
- Units will accept pans up to 6" deep (pans are not included)
- Drawer frames are heavy-duty stainless steel
- 12-Gauge stainless steel drawer slides with Delrin® rollers rated at 275 lbs
- Telescoping slides, with locking mechanism to prevent drawers from being pulled off of cabinet
- Heavy-duty pan locking divider supports are standard in drawers
- Compressor available on left or right, specify at time of unit order



OPTIONS & ACCESSORIES

- Stainless steel back
- Stainless steel interior
- Clear-lid models
- Overshelf kits
- Pan support
- 6" Casters, 6" black legs or seismic/flanged
- Composite cutting board
- Thermometer
- Night cover
- Remote option* (see note on back page)

REFRIGERATION SYSTEM

- Uses environmentally friendly, energy efficient R290 refrigerant, and meets all regulatory requirements for CARB, SNAP, DOE & more
- Adaptive defrost
- Epoxy coated evaporator coil
- Raised rail maintains temperatures between 36° - 38°F



Please verify qualifying units by visiting:
www.energystar.gov/cfs

3779 Champion Blvd., Winston-Salem, NC 27105
1-888-845-9800 Fax: 1-336-245-6453
Beverage-Air.com Sales@beva.com



BEVERAGE-AIR

MODEL	DPD72HC-4
EXTERNAL DIMENSIONAL DATA	
Width Overall	72"
Depth Overall with Cutting Board	37"
Height Overall with Casters	53 3/8"
Number of Drawers	4
Depth with Drawer Extended	55 3/8"
Drawer Opening	(4) 21 5/8" x 10 3/4"
Cutting Board	19"
INTERNAL DIMENSIONAL DATA	
NET Capacity (cubic ft.)	22.8
Internal Width Overall (in)	53"
Internal Depth Overall (in)	26"
Internal Height Usable (in)	23 7/8"
ELECTRICAL DATA	
Full Load Amperes	4.5
REFRIGERATION DATA	
Horsepower	1/2
Capacity (BTU/Hr)	2940
SHIPPING DATA	
Gross Weight - Crated	586 lbs
Height - Crated	46"
Width - Crated	75"
Depth - Crated	39"

*NOTE: Remote units are field wired and come with 6" legs. Refrigerant must be specified at time of order.

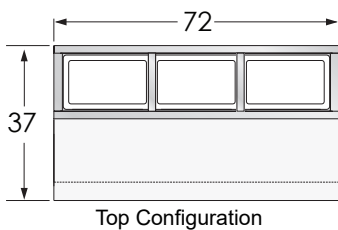

Deli/Pizza Preparation Table

Model: DPD72HC-4

Model Views

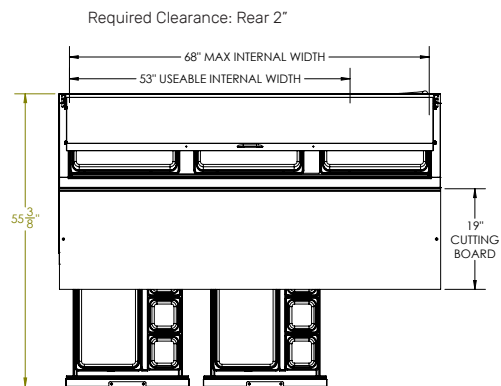

PLAN VIEW

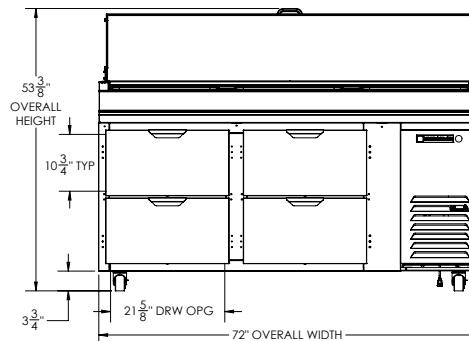

ELEVATION VIEW

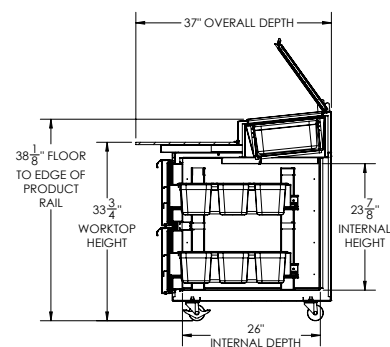

SIDE VIEW

*ELECTRICAL CONNECTION



115/60/1
NEMA 5-15P

Units pre-wired at factory and include 8' long cord and plug set.



3779 Champion Blvd., Winston-Salem, NC 27105 1-888-845-9800 Fax: 1-336-245-6453 Beverage-Air.com Sales@bevoir.com

an Ali Group Company



The Spirit of Excellence