



BEVERAGE-AIR

Project: _____	AIA#
Item: _____	
Location: _____	SIS#
Approved: _____	

BAR EQUIPMENT-BARMOBILE

MODEL:
BM23HC-B-28

BM23HC Portable Draft Beer Dispenser with No Draft Arm Hydrocarbon Series

BM23HC DRAFT BEER EQUIPMENT BARMOBILE

**3 Year Parts/Labor Warranty
Additional 4 Year Compressor Warranty**



CABINET CONSTRUCTION

- Exterior construction is wear resistant black vinyl on stainless steel
- Interior construction utilizes galvanized steel on walls and ceiling, doorsill is stainless steel, reinforced floor made from heavy duty stainless steel
- Top is made from heavy-duty stainless steel including drip tray
- Full electronic control
- No draft arm
- Beer waste bottle to capture beer from drain
- Self-closing door with lock, standard
- Magnetic door gaskets for positive door sealing
- Four-inch (4") heavy-duty casters
- Balanced, forced-air refrigeration system keeps beer in kegs ice cold for dispensing

OPTIONS & ACCESSORIES

- Club models available
- Custom tower hole location
- Drip tray location change
- Wine models available
- Wine tap
- Wine, beer & coffee faucet options
- 1- 4 faucet
- 2, 3, or 4-way manifold
- Draft arm faucet lock (slide-on)

REFRIGERATION SYSTEM

- Refrigeration system uses R290 refrigerant to comply with all environmental concerns
- Automatic, non-electric defrost
- Epoxy coated evaporator coil
- Maintains product temperatures between 36°F and 38°F



Please verify qualifying units by visiting:
www.energystar.gov/cfs

3779 Champion Blvd., Winston-Salem, NC 27105
1-888-845-9800 Fax: 1-336-245-6453
Beverage-Air.com Sales@bevair.com



BEVERAGE-AIR

MODEL	BM23HC-B-28
EXTERNAL DIMENSIONAL DATA	
Width Overall	24"
Depth Overall (with handle)	30 ³ / ₈ "
Height Overall (floor to top of glass rail)	39 ³ / ₈ "
Number of Doors	1
Depth with Door Open 90°	51"
Door Openings (in)	19 ⁷ / ₈ " x 27 ⁷ / ₈ "
INTERNAL DIMENSIONAL DATA	
NET Capacity (cubic ft.)	7.66
Internal Width Overall (in)	20"
Internal Depth Useable (in)	22 ¹ / ₄ "
Internal Height Overall (in)	29 ⁵ / ₈ "
ELECTRICAL DATA	
Full Load Amperes	2.0
REFRIGERATION DATA	
Horsepower	1/6
Capacity (BTU/Hr)*	1094
SHIPPING DATA	
Gross Weight - Crated	174 lbs
Height - Crated	43"
Width - Crated	27"
Depth - Crated	33"

KEG CAPACITIES: BM23 / DD24 / DD36

1 x 1/2 std. keg	4 x 1/6 keg	2 x 1/6 1 x 1/4 slim	2 x 1/4 slim

Bar Equipment-Portable Draft Beer Dispenser No Draft Arm Model: BM23HC-B-28

Model Views

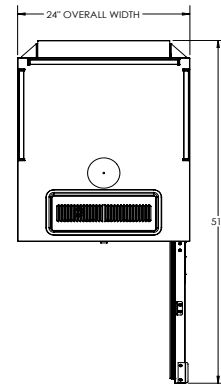

PLAN VIEW

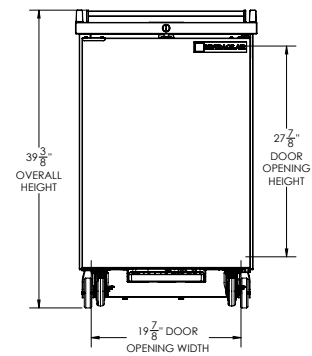

ELEVATION VIEW

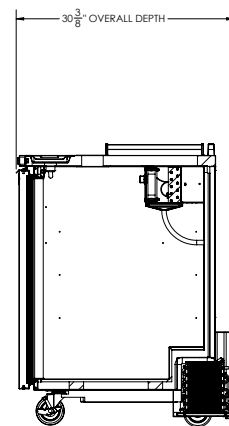

SIDE VIEW

*ELECTRICAL CONNECTION



115/60/1
NEMA 5-15P

Units pre-wired at factory
and include 8' long cord
and plug set.



3779 Champion Blvd., Winston-Salem, NC 27105 1-888-845-9800 Fax: 1-336-245-6453 Beverage-Air.com Sales@bevoir.com

an Ali Group Company



The Spirit of Excellence