



BEVERAGE-AIR

Project: _____	AIA#
Item: _____	
Location: _____	SIS#
Approved: _____	

P-SERIES TOP MOUNT ROLL-IN FREEZER
 PFI2HC-1AS Solid Door Freezer
 Hydrocarbon Series

MODEL:
PFI2HC-1AS

PFI2HC TOP MOUNT ROLL-IN FREEZER

3 Year Parts/Labor Warranty
Additional 4 Year Compressor Warranty

CABINET CONSTRUCTION



- Stainless steel front and side exterior (galvanized rear, back & bottom)
- Interior is made of corrosion resistant aluminum
- Stainless steel door liner
- Full electronic control
- Expansion valve technology
- Variable speed compressor technology
- Self-closing door with 120° stay-open feature
- 22 Gauge stainless steel doors
- LED interior light
- Heavy-duty cylinder locks
- Snap-in magnetic gaskets for positive door seal
- Hinged front shroud
- Reinforced stainless steel door ramps outside and cart guides inside
- Accepts carts up to 24 3/8" (W) x 26" (D) x 64 1/2" (H) (cart not included)
- Wiper gasket at bottom of door seals door to ramp
- Energy saving thermal breaker
- Stainless steel breaker caps
- 8' Cord and plug (see electrical data for details)

OPTIONS & ACCESSORIES

- Stainless steel interior
- Door swing orientation (at time of order)

REFRIGERATION SYSTEM

- Uses environmentally friendly, energy efficient R290 refrigerant, and meets all regulatory requirements for CARB, SNAP, DOE & more
- Adaptive defrost
- Epoxy coated evaporator coil, located out of the food zone
- Freezer capable of maintaining product temperature down to -10°F



Please verify qualifying units by visiting:
www.energystar.gov/cfs

3779 Champion Blvd., Winston-Salem, NC 27105
 1-888-845-9800 Fax: 1-336-245-6453
 Beverage-Air.com Sales@beva.com



BEVERAGE-AIR®

MODEL	PFI2HC-1AS
EXTERNAL DIMENSIONAL DATA	
Width Overall	68 ⁷ / ₈ "
Depth Overall with Handle	36 ¹ / ₄ "
Height Overall	84 ³ / ₈ "
Between Cart Guides	26"
Number of Doors	2
Depth with Door Open 90°	65 ³ / ₄ "
Door Opening (in)	27 ⁷ / ₈ " x 65 ¹ / ₂ "
INTERNAL DIMENSIONAL DATA	
NET Capacity (cubic ft.)	70.09
Internal Width Overall (in)	63 ⁵ / ₈ "
Internal Depth Overall (in)	26"
Internal Height Overall (in)	66 ¹ / ₄ "
ELECTRICAL DATA	
Full Load Amperes 115/60/1	13.9
REFRIGERATION DATA	
Horsepower	(2) 3/4
Capacity (BTU/Hr)	3854
SHIPPING DATA	
Gross Weight - Crated	750 lbs
Height - Crated	95"
Width - Crated	45"
Depth - Crated	78"

Top Mount Roll-in Freezer

Model: PFI2HC-1AS

Model Views

12" Top and 3" sides and rear clearance is required

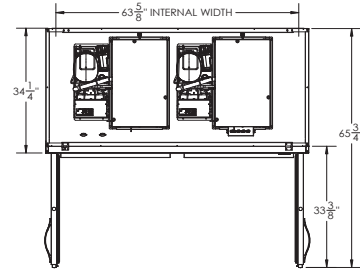

PLAN VIEW

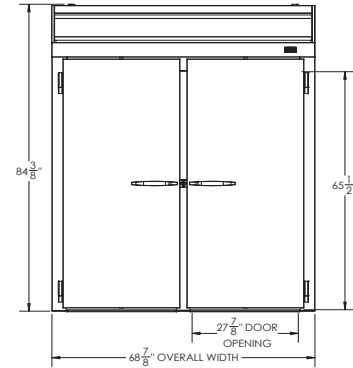

ELEVATION VIEW

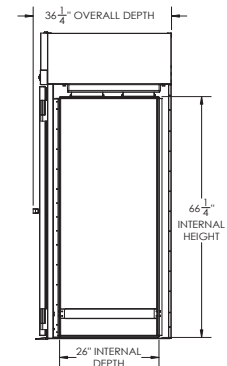

SIDE VIEW

ELECTRICAL CONNECTION



115/60/1
NEMA 5-20P

Unit pre-wired at factory and include 8' long cord and plug set.



3779 Champion Blvd., Winston-Salem, NC 27105 1-888-845-9800 Fax: 1-336-245-6453 Beverage-Air.com Sales@bevair.com

an Ali Group Company



The Spirit of Excellence