



BEVERAGE-AIR

Project: _____	AIA#
Item: _____	
Location: _____	SIS#
Approved: _____	

P-SERIES TOP MOUNT FREEZER

PF3HC-1AS Solid Door Reach-In Hydrocarbon Series

MODEL:
PF3HC-1AS

PF3HC Top Mount Freezer

3 Year Parts/Labor Warranty
Additional 4 Year Compressor Warranty



CABINET CONSTRUCTION

- Exterior stainless steel front and side (galvanized top, bottom & back)
- Interior is made of corrosion resistant aluminum
- Stainless steel door liner
- Full electronic control
- Expansion valve technology
- Variable speed compressor technology
- Self-closing doors with 120° stay-open feature
- 22 Gauge stainless steel doors
- LED interior light
- Cylinder locks
- Snap-in magnetic gaskets for positive door seal
- Hinged front shroud
- Energy saving thermal breaker
- Stainless steel breaker caps
- 9 Heavy-duty epoxy wire coated shelves
- 6" High adjustable stainless steel legs
- 8' Cord and plug (see electrical data for details)

OPTIONS & ACCESSORIES

- Stainless steel case back
- Stainless steel interior
- Additional shelves
- 3" or 6" casters
- 6" Seismic legs
- Tray slides (type A & A/C)
- Door swing orientation (at time of order)
- Remote option* (see note back on page)

REFRIGERATION SYSTEM

- Uses environmentally friendly, energy efficient R290 refrigerant, and meets all regulatory requirements for CARB, SNAP, DOE & more
- Adaptive defrost
- Epoxy coated evaporator coil, located out of the food zone
- Freezer capable of maintaining product temperature down to -10°F



Please verify qualifying units by visiting:
www.energystar.gov/cfs

3779 Champion Blvd., Winston-Salem, NC 27105
1-888-845-9800 Fax: 1-336-245-6453
Beverage-Air.com Sales@bevair.com



BEVERAGE-AIR®

MODEL	PF3HC-1AS
EXTERNAL DIMENSIONAL DATA	
Width Overall	77 3/4"
Depth Overall with Handle	34 7/8"
Height Overall	84 1/8"
Number of Doors	3
Depth with Door Open 90°	57 1/2"
Door Opening (in)	21 1/2" x 54 5/8"
INTERNAL DIMENSIONAL DATA	
NET Capacity (cubic ft.)	68.34
Internal Width Overall (in)	73 3/4"
Internal Depth Overall (in)	26"
Internal Height Overall (in)	56 5/8"
No. of Shelves	9
ELECTRICAL DATA	
Full Load Amperes* 115/60/1	13.9
REFRIGERATION DATA	
Horsepower	(2) 3/4
Capacity (BTU/Hr)	4900
SHIPPING DATA	
Gross Weight (crated lbs)	800 lbs
Height - Crated	87"
Width - Crated	45"
Depth - Crated	87"

*NOTE: Remote units are field wired and come with 6" legs.
Refrigerant must be specified at time of order.

Top Mount Freezer Model: PF3HC-1AS

Model Views

12" Top and 3" side and rear clearance is required

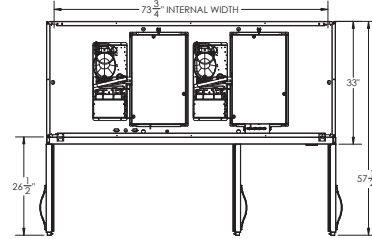

PLAN VIEW

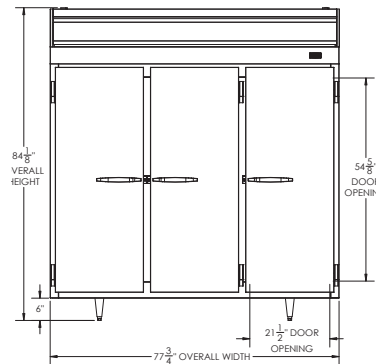

ELEVATION VIEW

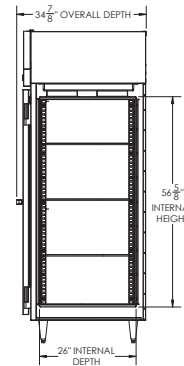

SIDE VIEW

*ELECTRICAL CONNECTION



115/60/1
NEMA 5-20

Unit pre-wired at factory
and include 8' long cord
and plug set.



an Ali Group Company



The Spirit of Excellence

3779 Champion Blvd., Winston-Salem, NC 27105
1-888-845-9800 Fax: 1-336-245-6453
Beverage-Air.com Sals@bevair.com