



# BEVERAGE-AIR

Project: _____	AIA#
Item: _____	
Location: _____	SIS#
Approved: _____	

## P-SERIES TOP MOUNT FREEZER

### PF2HC-1AS Solid Door Reach-In Hydrocarbon Series

**MODEL:**  
**PF2HC-1AS**



**3 Year Parts/Labor Warranty**  
**Additional 4 Year Compressor Warranty**

### CABINET CONSTRUCTION

- Exterior stainless steel front and side (galvanized top, bottom & back)
- Interior is made of corrosion resistant aluminum
- Stainless steel door liner
- Full electronic control
- Expansion valve technology
- Self-closing doors with 120° stay-open feature
- 22 Gauge stainless steel doors
- LED interior light
- Cylinder locks
- Snap-in magnetic gaskets for positive door seal
- Hinged front shroud
- Energy saving thermal breaker
- Stainless steel breaker caps
- 6 Heavy-duty epoxy wire coated shelves
- 6" High adjustable stainless steel legs
- 8' Cord and plug (see electrical data for details)

### OPTIONS & ACCESSORIES

- Stainless steel case back
- Stainless steel interior
- Additional shelves
- 3" or 6" casters
- 6" Seismic legs
- Tray slides (type A & A/C)
- Door swing orientation (at time of order)
- Remote option\* (see note back on page)

### REFRIGERATION SYSTEM

- Uses environmentally friendly, energy efficient R290 refrigerant, and meets all regulatory requirements for CARB, SNAP, DOE & more
- Adaptive defrost
- Epoxy coated evaporator coil, located out of the food zone
- Freezer capable of maintaining product temperature down to -10°F

**PF2HC Top Mount Freezer**



Please verify qualifying units by visiting:  
[www.energystar.gov/cfs](http://www.energystar.gov/cfs)

3779 Champion Blvd., Winston-Salem, NC 27105  
1-888-845-9800 Fax: 1-336-245-6453  
Beverage-Air.com Sales@bevair.com



# BEVERAGE-AIR®

MODEL	PF2HC-1AS
<b>EXTERNAL DIMENSIONAL DATA</b>	
Width Overall	52 1/8"
Depth Overall with Handle	34 7/8"
Height Overall	84 1/8"
Number of Doors	2
Depth with Door Open 90°	57 1/2"
Door Opening (in)	21 1/2" x 54 5/8"
<b>INTERNAL DIMENSIONAL DATA</b>	
NET Capacity (cubic ft.)	44.57
Internal Width Overall (in)	48 1/8"
Internal Depth Overall (in)	26"
Internal Height Overall (in)	56 5/8"
No. of Shelves	6
<b>ELECTRICAL DATA</b>	
Full Load Amperes* 115/60/1	10.5
<b>REFRIGERATION DATA</b>	
Horsepower	3/4+
Capacity (BTU/Hr)	2580
<b>SHIPPING DATA</b>	
Gross Weight (crated lbs)	550 lbs
Height - Crated	87"
Width - Crated	60"
Depth - Crated	45"

\*NOTE: Remote units are field wired and come with 6" legs.  
Refrigerant must be specified at time of order.

## Top Mount Freezer Model: PF2HC-1AS

### Model Views

12" Top and 3" side and rear clearance is required

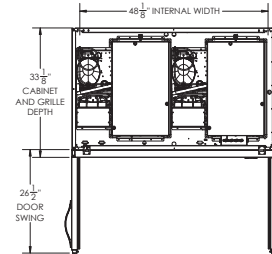

### PLAN VIEW

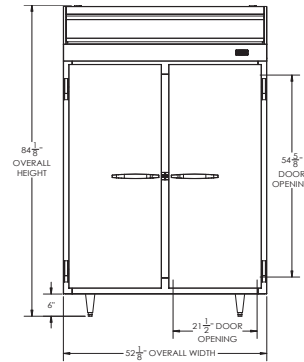

### ELEVATION VIEW

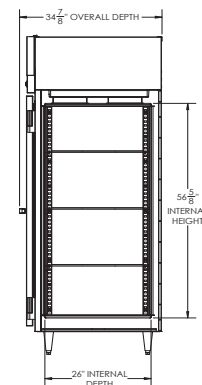

### SIDE VIEW

### \*ELECTRICAL CONNECTION



115/60/1  
NEMA 5-15P

Unit pre-wired at factory  
and include 8' long cord  
and plug set.



an Ali Group Company



The Spirit of Excellence

3779 Champion Blvd., Winston-Salem, NC 27105  
1-888-845-9800 Fax: 1-336-245-6453  
Beverage-Air.com Sals@bevair.com