

Models □ W4-B PKG

PRODUCT:

QUANTITY:

ITEM:

Designed Smart

Equipment Packages to fit your Operations!

Available in a style to fit your operation:

- High impact “Nacho Cheese” and “Buttery Popcorn” signs build impulse sales of these key snack items.
- Comes in a 4 quart inset and ladle package.

Designed to Deliver Dependable, Safe Temperatures

- Unit heat quickly and have fast recovery for unexpected surges in demand.
- Double boiler construction maintains a temperature of up to 140 degrees.
- Infinite control heat system offers more accuracy than toggle switch systems.

Easy to operate

- W-4 holds a standard #10 size can.
- Heated warmer is provided with 4 qt inset, slotted hinged cover and 1 oz ladle. Just empty sauce or butter into inset, heat and ladle out over meals or snacks.
- Unit is compact and portable.
- Unit is fully insulated to focus heat on interior warming area and to keep outside surfaces safe.

Easy to Maintain

- Heated 4 Quart Warmers are designed to require minimal labor:
- Stainless steel exteriors are easy to wipe clean.



Hot Butter Warmer

Graphics Options

Graphics	Transparency	Decal
•Nacho Cheese	217701	217657
•Buttery Popcorn	217703	217659
•Hot Chili	217702	217658
•Hot Fudge	217704	217661

APW Wyott Design Features

- Exterior cabinet is constructed of stainless steel for maximum durability.
- Made with heavy duty wiring
- Units are fully insulated to focus heat on interior warming area and to keep outside surfaces safe.

Reliability backed by APW Wyott's Warranty

All APW Wyott Heated Pump Warmers and Heated Countertop 4 Quart Warmers are backed by a 1-year limited warranty and a 1-year on-site labor warrant.

•Certified by the following agencies:



*Warranty does not include rock grates, cooking grates, burners shields or fireboxes.

See reverse side for product specifications.

Models □ LCCW □ CCW □ W4-B PKG □ LW-4 PKG

PRODUCT:

QUANTITY:

ITEM:

Heated Pump Warmers

LCCW

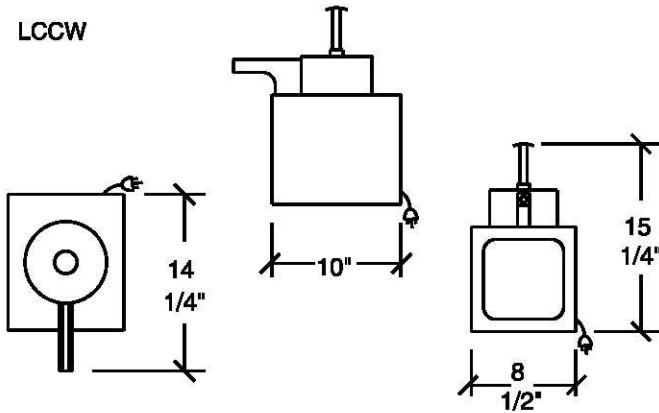

PRODUCT SPECIFICATIONS

Heated Pump Warmers

Construction:

Stainless steel construction with aluminum alloy heated spout. Direct action pump. 1/2" tall rubber feet.

Electrical Specifications:

CCW: 120V, 396W, 3.3 Amps
 240V, 396W, 1.6 Amps
 LCCW: 120V, 420W, 3.4 Amps
 240V, 420W, 1.7 Amps

Overall Dimensions:

CCW: 15 1/4"H x 8 1/2"W x 14 1/4"D
 (38.6 cm x 21.6 cm x 36.2 cm)
 LCCW: 15 1/4"H x 8 1/2"W x 14 1/4"D
 (38.6 cm x 21.6 cm x 36.2 cm)

Heated Countertop 4 Quart Warmers

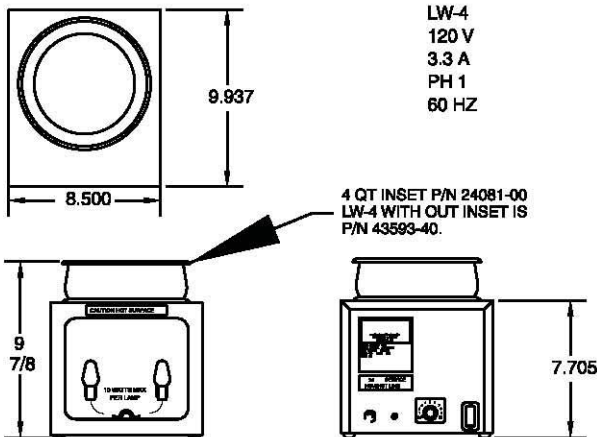

LW-4
 120 V
 3.3 A
 PH 1
 60 HZ

Shipping Weight:

CCW : 12 lbs (5.5kg)
 LCCW: 12 lbs (5.5kg)

FOB: Cheyenne, WY 82007

PRODUCT SPECIFICATIONS

Heated 4 Quart Warmers

Construction:

Stainless steel construction. Comes with 4 quart inset, hinged cover, 1 oz. ladle and decal. 1/2" tall rubber feet.

Electrical Specifications:

W-4B PKG: 120V, 396W, 3.3 Amps
 LW-4B PKG: 120V, 396W, 3.3 Amps

Overall Dimensions:

W-4B PKG: 10 3/4"H x 9 1/2"W x 9 1/2"D
 (27.3 cm x 24.1 cm x 24.1 cm)
 LW-4 PKG: 9 7/8"H x 8 1/2"W x 9 15/16"D
 (19.6 cm x 21.6 cm x 25.2 cm)

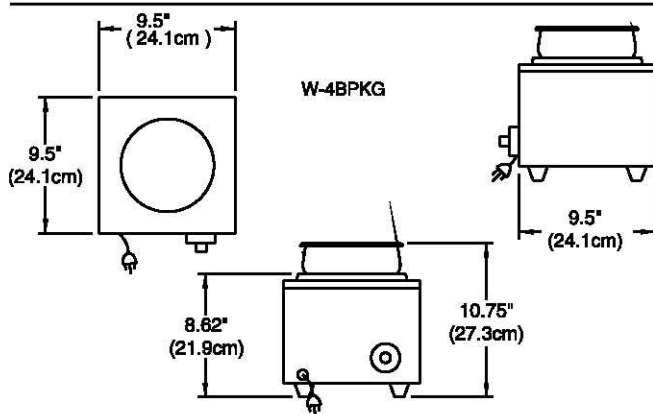

*APW Wyatt reserves the right to modify specifications or discontinue models without incurring obligation.