

100-CW Series Cold Food Drop-In Well

ALTO-SHAAM.

Safely hold cold food while maintaining food temperature and quality with Alto-Shaam cold wells. Cold wall, conductive cooling eliminates the need for forced air that degrades food quality. A digital thermostat holds food at the ideal temperature for any cold dish. Complete the look with complementing waterless round and hot food wells.



100-CW

Standard features

- Cold wall drop-in refrigerated cold display pan
- Meets NSF Std. #7 for cold holding at 41°F [5°C] or below
- Digital thermostat provides cold holding temperature flexibility
- Exterior body is corrosion resistant steel
- Insulated with CFC free, foamed in place polyurethane
- Recessed, stainless steel ledge provided for supporting pans, adaptor bars included
- Stainless steel top and coved corner interior
- Dual air movement louver
- Condensing unit mounted on a swivel platform that allows for 90 degrees of rotation of intake/exhaust louver, giving the option of mounting the louver on any side
- Includes two (2) 20" [508mm] pan divider bars

Model (chose one)

- 100-CW: Self-contained 1/4 hp compressor
- 100-CW/R: For use with a remote compressor

Accessories

- Remote on/off switch; 8' [2438mm] extension (contact factory for cutout) [SW-35840]

Pan divider bars

- 12" [305mm] for half-size/third-size pans [1014395]



CAPACITY

- 1 One full-size or GN 1/1 pan
 - 2 Two half-size or GN 1/2 pans
 - 3 Three third-size or GN 1/3 pans
- 36 lb [16,3 kg] product maximum*
22 qt [21 L] volume maximum*

*Based on 6" [152mm] deep pans. Will also accept 2/12" [65mm] and 4" [102mm] deep pans.



100-CW Series



Specification

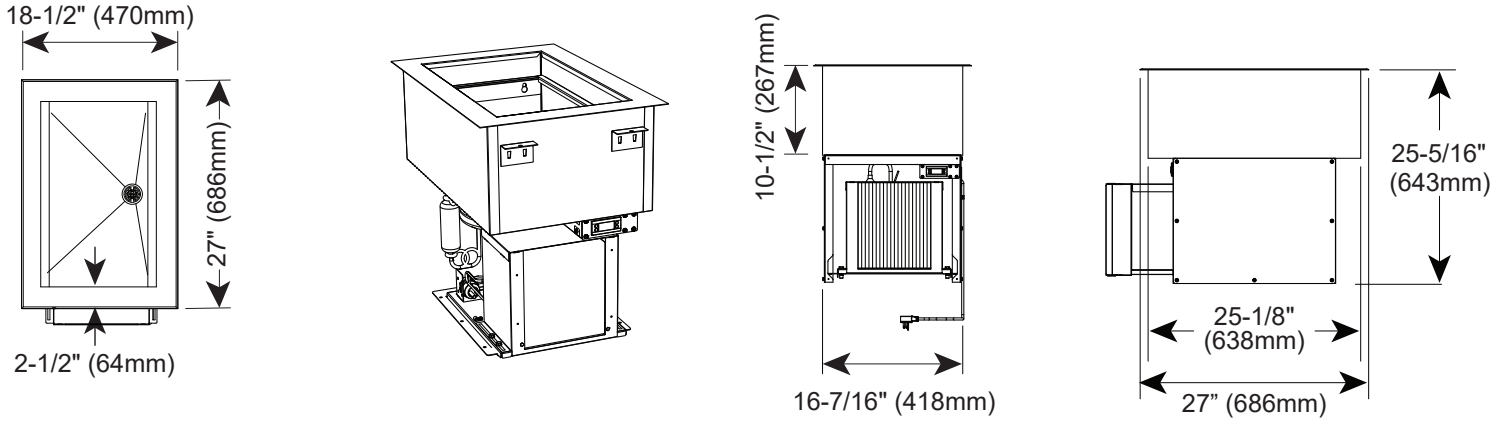

DIMENSIONS

Exterior (H x W x D)

25-5/16" x 18-1/2" x 27" [643mm x 470mm x 686mm]

Counter Cutout (L x W)

16-7/8" x 25-1/2" [429mm x 648mm]

Net Weight

140 lb (64 kg)

Ship Weight*

171 lb (78 kg)

*Domestic ground shipping information. Contact factory for export weight and dimensions.

Contact factory for 100-CW/R information.

Interior (H x W x D)

8-3/4" x 13-11/16" x 21-7/8" [222mm x 348mm x 556mm]

Dual Air Movement Louver Cutout (H x W)

21-1/2" x 15" [546mm x 381mm]

Ship Dimensions (L x W x H)*

31-3/4" x 23-1/4" x 36" [806mm x 591mm x 914mm]



CHECK FIRST

- The countertop material must be water resistant.
- A distance of 3/4" [19mm] or more is required between the top rims of the wells to ensure easy cleaning.
- Appliance must be installed level.
- Appliance must not be installed in any area where it may be directly affected by steam, grease, dripping water, high temperatures, or any other severely adverse conditions.
- Appliance must not be installed under a hood.
- Avoid installing appliance under a 4-way ceiling diffuser.
- Outdoor use is not recommended.
- A water drain or water catch basin is required for appliance.
- LED lighting is recommended for overhead lighting.
- Requires R290 refrigerant.



CLEARANCE

4" [102mm] in front of dual air movement louver



ELECTRIC

100-CW	V	Ph	Hz	A	kW	Cord & Plug
115V	115	1	60	5.0	0.6	NEMA 5-15p 15A-125V plug 9' [229mm] long cord

Remote BTU Requirements

Low Temperature compressor: -10°F [-23°C] suction line
BTU load: 249*

*Does not include line run for remote compressor

CONTACT US

W164 N9221 Water Street | Menomonee Falls, Wisconsin 53051 | U.S.A.

Phone: 262.251.3800 | 800.558.8744 U.S.A./Canada | Fax: 262.251.7067 | alto-shaam.com