



HEAVY DUTY REFRIGERATED COLD WELL TABLES WITH ENCLOSED BASE



Item #: _____ Qty #: _____
 Model #: _____
 Project #: _____

Enclosed Base
 HDRCP-3-BS Shown
 with Optional TA-255P Casters

NOTE: Units are not designed to cool foods originally warm. Food should already be chilled to maintain the proper temperatures

FEATURES:

- Heavy duty construction
- All welded 300 series stainless steel
- High nominal cooling capacity for consistent product temperature control
- Aluminum encased copper tube evaporator panels improve heat transfer by increasing contact area
- This increases operating efficiency and reduces power consumption
- Expansion valve for efficient operation at various temperature conditions
- Refrigerant filter drier to insure cleanliness of sealed refrigeration circuit
- Sight glass to insure a properly charged refrigeration system
- Liquid receiver for improved refrigerant charge control
- Low running current suitable for any 115 volt circuit
- Precision electronic thermostat for exact temperature control
- Includes adapter bars for use with standard 12" x 20" pans
- Stainless steel shelf with removable 3/8" thick poly cutting board - Ships K.D.

For Mobile Units:

- SU-25** - 5" swivel casters, two with brakes
- Universal mount push handle (right/left) on mobile units

MATERIAL:

TOP: 18 gauge, #304 stainless steel, with black polyethylene thermal breaker marine edge

BODY: 18 gauge #304 stainless steel

LINER: Constructed of 18 gauge, 304 stainless steel, with 3" recessed top, one piece construction, all welded, ground and polished to a uniform finish. All corners are covered with a 1/4" radius. Liner is pitched towards a 1" I.P.S. drain

CUTTING BOARD: White Thermoplastic

LEGS: 16 gauge stainless steel with full adjustable stainless steel bullet foot

REFRIGERATION SYSTEM: The compressor is housed in a 16 gauge galvanized under structure, fabricated from formed angles and bolted to the galvanized jacket. The fully self contained condensing unit is provided with a hermetically sealed compressor with a digital, programmable thermostat. The system is fully charged with environmentally friendly R404-A refrigerant

ELECTRICAL:

Unit will be wired for 15 amps, 120V single phase operation with an on/off thermostat switch

2-3 well Units: 115 V, 8 AMPS, 60 Hz, 1/5 HP

4-6 well Units: 115 V, 8 AMPS, 60 Hz, 1/3 HP

Includes 6 ft. long, 3 wire cord with a NEMA 5-15P plug

Model	Length (L)	Width* (A x B)	O.A. Inside Well Dim (A x B)	Drain Distance (C & D)	Refrigerant	Wt (lbs.)	Cu. Ft.
HDRCP-2-BS	31-13/16"	36.25"	28.75" x 22"	4.51" x 27.356"	R404-A	320	24
HDRCP-3-BS	47-1/8"	36.25"	42.25" x 22"	5.465" x 41.715"	R404-A	420	36
HDRCP-4-BS	62-1/2"	36.25"	55.75" x 22"	6.371" x 56.121"	R404-A	510	50
HDRCP-5-BS	77-3/4"	36.25"	69.25" x 22"	7.277" x 70.527"	R404-A	568	62
HDRCP-6-BS	93-1/8"	36.25"	82.75" x 22"	8.183" x 84.933"	R404-A	633	74

*Width Includes 8" Cutting Board



SU-P-234 - 6' with NEMA 5-15 plug Included

OPTIONAL CASTERS

Visit our website for additional Food Table Accessories



SU-26

WARNING: Refrigerated Equipment on this page may expose you to chemicals, including Ethanes, that are known to the State of California to cause cancer or birth defects or other reproductive harm. For more Info, visit www.p65warnings.ca.gov.

Customer Service Available To Assist You 1-800-645-3166 8:30 am - 7:00 pm E.S.T.

For Orders & Customer Service:
 Email: customer@advancetabco.com or Fax: 631-242-6900

For Smart Fabrication™ Quotes:
 Email: smartfab@advancetabco.com or Fax: 631-586-2933

DIMENSIONS and SPECIFICATIONS

TOL ± .125"

ALL DIMENSIONS ARE TYPICAL

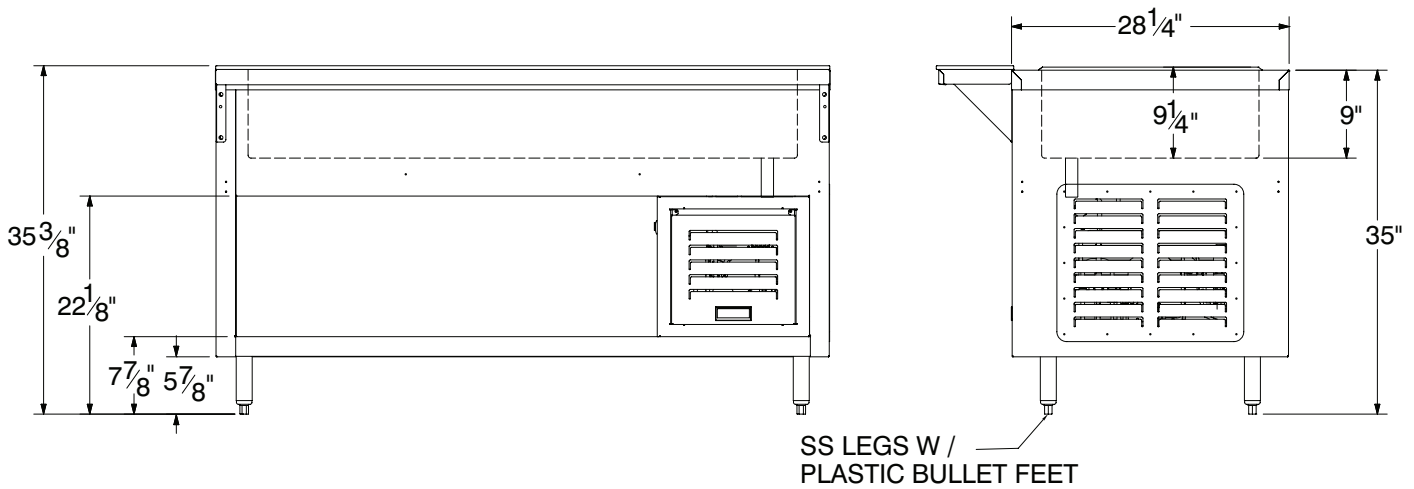
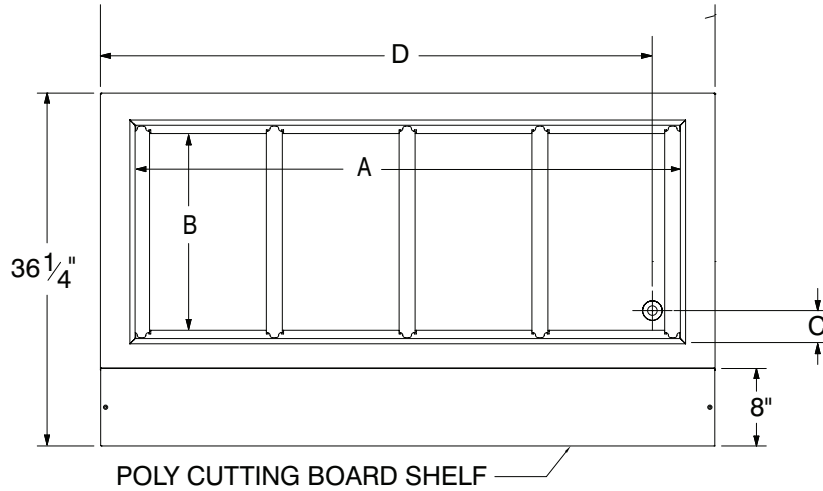

Food Table Shelving & Accessories

Visit our website for additional accessories



Double Sided Self-Serve Buffet Shelf with Built-In Food Shield

Model	Length	Approx Wt.	Cu. Ft.
TBS-2	31-13/16"	34 lbs.	2
TBS-3	47-1/8"	42 lbs.	3
TBS-4	62-7/16"	47 lbs.	4
TBS-5	77-3/4"	55 lbs.	4
TBS-6	93-1/8"	63 lbs.	4

Acrylic Side Panels for Buffet Shelf
Add side panels to meet additional NSF requirements (2 panels per end)
TBP-1 One End
TBP-2 Two Ends
Field Installation Available



Single Sided Cafeteria Shelf with Built-In Food Shield

Model	Length	Approx Wt.	Cu. Ft.
TSS-2	31-13/16"	18 lbs.	2
TSS-3	47-1/8"	23 lbs.	3
TSS-4	62-7/16"	30 lbs.	4
TSS-5	77-3/4"	35 lbs.	4
TBS-6	93-1/8"	41 lbs.	4

Acrylic Side Panel for Serving Shelf
Add side panels to meet additional NSF requirements. (1 panel per end)
TSP-1 One end
TSP-2 Two Ends
Field Installation Available



ADVANCE TABCO is constantly engaged in a program of improving our products. Therefore, we reserve the right to change specifications without prior notice.