

BLACK◆DIAMOND

Standard Series Gas Charbroilers - BDECTC Series

Black Diamond's Standard Series radiant gas countertop charbroilers are designed for use with either natural or LP gas. Constructed of stainless steel front and sides that are fully welded, these units are able to stand the toughest of kitchen environments. Each unit includes tips for field conversion to LPG.



BDECTC-16/NG
BDECTC-24/NG
BDECTC-36/NG
BDECTC-48/NG

Standard Features

- ◆ Fully welded stainless steel front bullnose design with galvanized sides
- ◆ Fully welded stainless steel backsplash for extra durability
- ◆ 30,000 BTU per burner
- ◆ One stainless steel burner every 12" grate width
- ◆ Cast iron grill grates are reversible and height adjustable
- ◆ 4"-5" adjustable legs
- ◆ Separate gas valves for each burner with standing pilot ignition system
- ◆ Removable stainless steel drip tray for easy cleaning
- ◆ 3/4" rear NPT gas inlet
- ◆ ETL Listed and ETL Sanitation

Black Diamond warrants this product to be free of defects in materials and workmanship for period of 1 year from the date of original installation.



Model	Overall Width	Burners	Total BTU	Net Weight (lb)	Gross Weight (lb)
BDECTC-16/NG	16"	1	30,000	95	121
BDECTC-24/NG	24"	2	60,000	119	154
BDECTC-36/NG	36"	3	90,000	163	218
BDECTC-48/NG	48"	4	120,000	244	359

BLACK◆DIAMOND

Standard Series Gas Charbroilers - BDECTC Series

Plan View

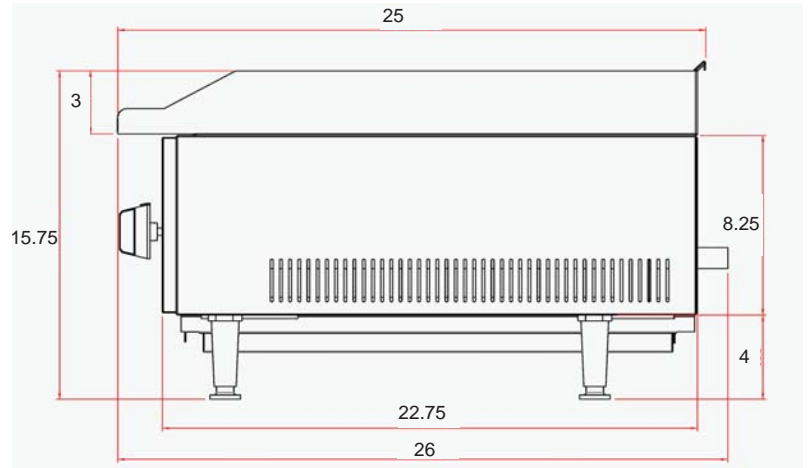
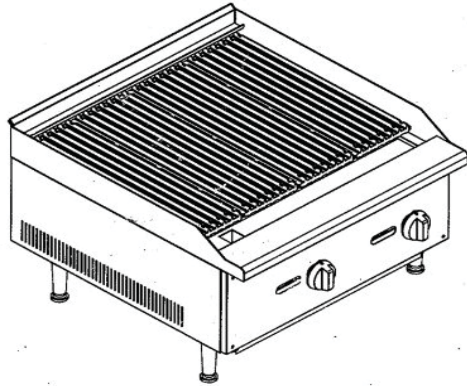

Unit Dimensions (inches)

Model	Description	Width	Depth	Height
BDECTC-16/NG	16" Charbroiler	16	26	15.75
BDECTC-24/NG	24" Charbroiler	24	26	15.75
BDECTC-36/NG	36" Charbroiler	36	26	15.75
BDECTC-48/NG	48" Charbroiler	48	26	15.75

Drip Tray (inches)

Model	Width	Depth	Height	Drip Tray Qty
BDECTC-16/NG	11.5	21	1	1
BDECTC-24/NG	20.75	20.75	1	1
BDECTC-36/NG	31.5	20.75	1	1
BDECTC-48/NG	20	20.75	1.25	2