



**John
BOOS**
Since 1887

ITEM #: _____ QTY: _____
 MODEL #: _____
 PROJECT NAME: _____

062420

3601 S. Banker St. Effingham, IL 62401 • P.O. BOX 609 • Ph: (888) 431-2667 • Fax: (800) 433-2667

"4CS6R1.5" MODULAR BASE WORK TABLES - 16GA TOP

SLIDING DOOR STYLE - 1-1/2" REAR RISER



FEATURES:

- ENCLOSED BASE WORK TABLES - **SLIDING DOOR STYLE**
- **1-1/2" REAR RISER** WITH STALLION EDGE ON FRONT AND 90 DEGREE SIDE EDGE BEND DOWN FOR TABLE LINE-UP
- TOP IS SOUND DEADENED REINFORCED WITH 2"X3" CHANNEL RUNNING ENTIRE LENGTH OF TOP
- STAINLESS STEEL LEG WITH ADJUSTABLE FEET
- FIXED OR ADJUSTABLE INTERMEDIATE SHELF AVAILABLE
- 36" WORKING HEIGHT
- SHIPPED STANDARD WELDED SET-UP



CONSTRUCTION:

- TOP: STAINLESS STEEL CABINET TOPS TIG WELDED, EXPOSED WELDS ARE POLISHED TO MATCH ADJACENT SURFACE #4 POLISHED, SATIN FINISH
- REMOVABLE STAINLESS STEEL LEGS
- SLIDING DOORS ARE CONSTRUCTED AS DOUBLE PANEL DOORS

MATERIAL:

- TOP: 16GA TYPE 300 STAINLESS STEEL WITH #4 POLISH, SATIN FINISH
- BODY: 18GA TYPE 430 STAINLESS STEEL
- LEGS: STAINLESS STEEL WITH ADJUSTABLE FEET



STALLION EDGE

INTERMEDIATE SHELF IS AVAILABLE IN FIXED OR ADJUSTABLE

- FIXED MID SHELF ADD: "-1S"
- ADJ MID SHELF ADD: "-1AS"

24" WIDE

MODEL	QTY
4CS6R1.5-2448	
4CS6R1.5-2460	
4CS6R1.5-2472	
4CS6R1.5-2484	
4CS6R1.5-2496	
4CS6R1.5-24108	
4CS6R1.5-24120	
4CS6R1.5-24132	
4CS6R1.5-24144	

30" WIDE

MODEL	QTY
4CS6R1.5-3048	
4CS6R1.5-3060	
4CS6R1.5-3072	
4CS6R1.5-3084	
4CS6R1.5-3096	
4CS6R1.5-30108	
4CS6R1.5-30120	
4CS6R1.5-30132	
4CS6R1.5-30144	

36" WIDE

MODEL	QTY
4CS6R1.5-3648	
4CS6R1.5-3660	
4CS6R1.5-3672	
4CS6R1.5-3684	
4CS6R1.5-3696	
4CS6R1.5-36108	
4CS6R1.5-36120	
4CS6R1.5-36132	
4CS6R1.5-36144	

DETAILED SPECIFICATIONS

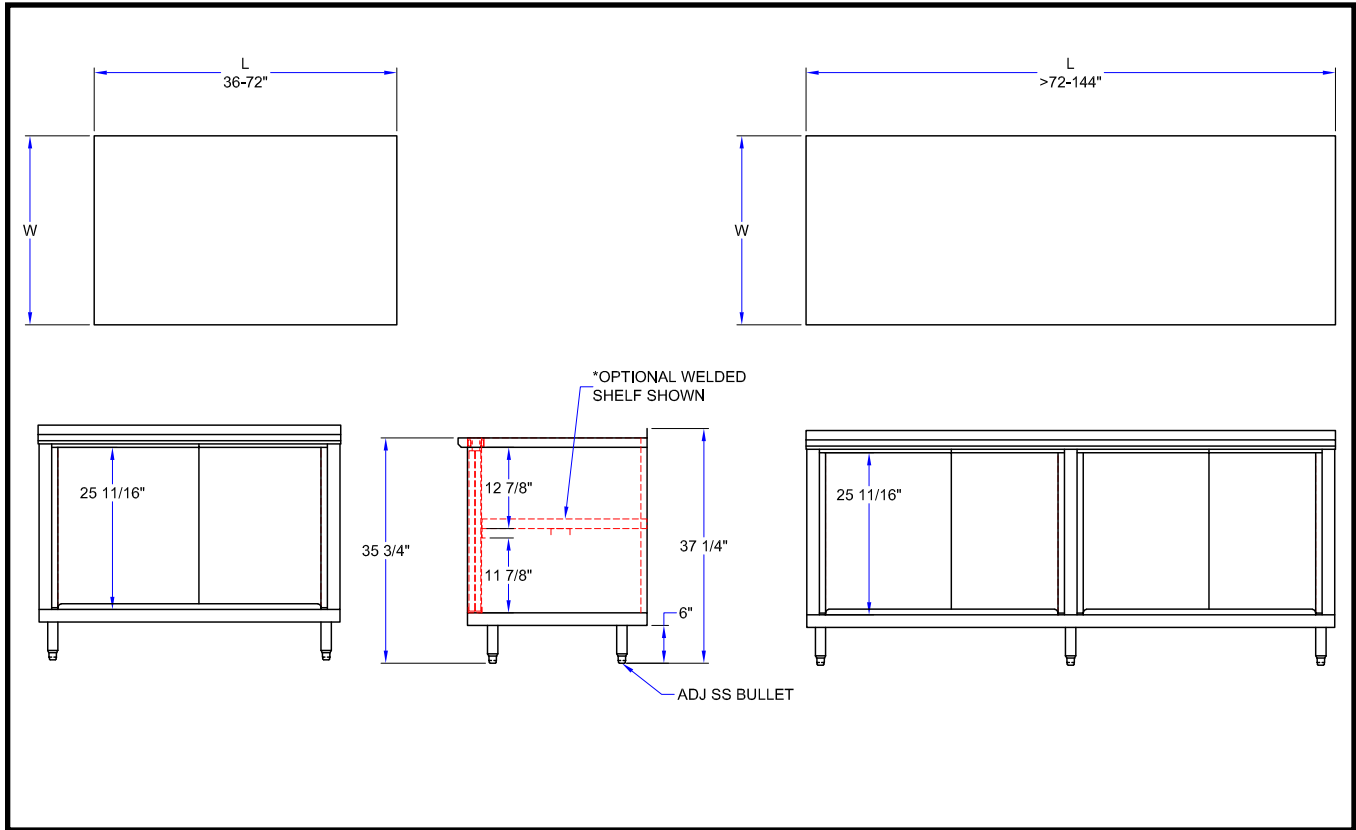

24" WIDE

LENGTH	MODEL	WT. (LBS)
48"	4CS6R1.5-2448	152
60"	4CS6R1.5-2460	182
72"	4CS6R1.5-2472	213
84"	4CS6R1.5-2484	259
96"	4CS6R1.5-2496	290
108"	4CS6R1.5-24108	320
120"	4CS6R1.5-24120	351
132"	4CS6R1.5-24132	380
144"	4CS6R1.5-24144	411

30" WIDE

LENGTH	MODEL	WT. (LBS)
48"	4CS6R1.5-3048	167
60"	4CS6R1.5-3060	200
72"	4CS6R1.5-3072	231
84"	4CS6R1.5-3084	283
96"	4CS6R1.5-3096	316
108"	4CS6R1.5-30108	349
120"	4CS6R1.5-30120	380
132"	4CS6R1.5-30132	413
144"	4CS6R1.5-30144	446

36" WIDE

LENGTH	MODEL	WT. (LBS)
48"	4CS6R1.5-3648	181
60"	4CS6R1.5-3660	216
72"	4CS6R1.5-3672	251
84"	4CS6R1.5-3684	307
96"	4CS6R1.5-3696	342
108"	4CS6R1.5-36108	376
120"	4CS6R1.5-36120	411
132"	4CS6R1.5-36132	446
144"	4CS6R1.5-36144	481

MODEL # STRUCTURE

R = RISER
 6 = 16 GAUGE
 CS = S.S. CABINET SLIDING DOORS
 4 = 430 STAINLESS STEEL WRAP

1.5 = 1-1/2" REAR RISER
 24 = WIDTH - FRONT TO BACK
 48 = LENGTH - LEFT TO RIGHT

4CS6R1.5-2448

SOME UNITS SHIP UNASSEMBLED FOR REDUCED SHIPPING COST. ALL DIMENSIONS ARE TYPICAL. TOLERANCE +/- .500"

John Boos & Co. is constantly engaged in a program of improving products and therefore reserves the right to change specifications without prior notice.



3601 S. Banker St. • Effingham, IL 62401 • PO BOX 609 • quotes@johnboos.com

021819



www.johnboos.com

532